

**Wall mounted
Vision 75 cm
Black**



EAN 5414425221929

Energy label

▪ Lighting Efficiency class (LEhood)	A
--------------------------------------	---

Functions & features

▪ Control method	Touch control
▪ Number of speeds	3 + power
▪ Automatic Power revert (minutes)	6
▪ Motor	Integrated
▪ Sound absorber	Integrated
▪ Recirculation	Standard, Monoblock
▪ InTouch function	Optional
▪ Auto stop	▪
▪ Delayed switch off (minutes)	30
▪ Number of grease filters	2
▪ Grease filter	7830020
▪ Grease filter cleaning indication	▪
▪ Recirculation filter cleaning indication	▪

Dimensions

▪ Product dimensions exhaust (WxDxHmin-Hmax) (mm)	748 x 426 x 517 -
▪ Product dimensions recirculation (WxDxHmin-Hmax) (mm)	748 x 426 x -
▪ Advised mounting height induction hobs (Hmin-Hmax) (mm)	500 - 750
▪ Advised mounting height gas hobs (Hmin-Hmax) (mm)	650 - 750
▪ Advised mounting height ceramic hobs (Hmin-Hmax) (mm)	500 - 750
▪ Position exhaust	Top

Lighting

▪ Functional lighting type	Led
▪ Dimmable light	-
▪ Soft-ON/OFF	-
▪ Total energy consumption functional light (W)	7

Airflow and noise level

▪ Free airflow (m ³ /h)	800
▪ Airflow (m ³ /h) measured according to EN 61591	
▪ Sound regulation according to EN 60704-2-13	
▪ Airflow speed 1 (m ³ /h)	126
▪ Airflow speed 2 (m ³ /h)	191
▪ Airflow speed 3 (m ³ /h)	418
▪ Airflow Powerspeed (m ³ /h)	478
▪ Sound pressure speed 1 (dB(A)) / Sound power speed 1 (dB(A))	34 / 45
▪ Sound pressure speed 2 (dB(A)) / Sound power speed 2 (dB(A))	45 / 55
▪ Sound pressure speed 3 (dB(A)) / Sound power speed 3 (dB(A))	53 / 64

Airflow and noise level

- Sound pressure Powerspeed (dB(A)) / Sound Powerspeed (dB(A)) 59 / 70

Technical specifications

- Maximum power 325
- Voltage (V) 220-230
- Frequency (Hz) 50
- Length power supply cord (m) 1,3
- Power consumption in stand-by-mode (Ps) (W) 0.29
- Net weight (kg) 34

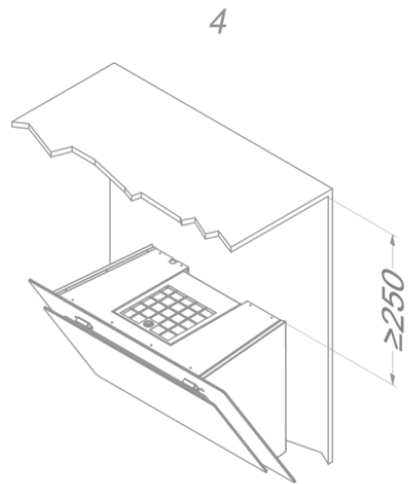
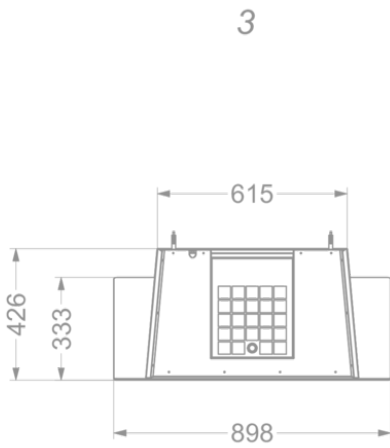
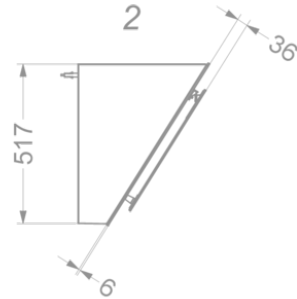
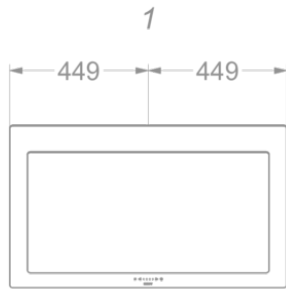

Accessories

Control kit

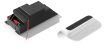

990021

InTouch Kit incl. remote control

