

## A2-81 New product

100cm "Opera" Dual Cavity Cooker with Multifunction  
Oven and Gas hob, Stainless Steel  
Energy rating AB

EAN13: 8017709256746

MAIN OVEN



- 9 functions
- Oven capacity: gross 70 litres, net 61 litres
- Usable cavity space dimensions (HxWxD): 316x460x412mm

Touch timer display

Eclipse black glass

- Air cooling system
- Closed door grilling
- Triple glazed removable door
- Easy clean enamel interior
- Metal side supports, 4 cooking levels
- Stay clean liners

Vapor clean function

AUXILIARY OVEN



- 6 functions
- Oven capacity: gross - 36 litres, net - 35 litres
- Usable cavity space dimensions (HxWxD): 310x255x417mm

Eclipse black glass

- Triple glazed removable door
- Air cooling system
- Closed door grilling
- Easy clean enamel interior
- Metal side supports, 4 cooking levels
- Roof liner
- Pull out full width storage drawer beneath the ovens

HOB

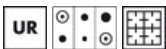

- 6 burners
- Rear left: Ultra rapid 4.20 kW
- Front left: 1.80 kW
- Rear centre: 1.80 kW
- Front centre: 1.00 kW
- Rear right: Rapid 3.00 kW
- Front right: Ultra rapid 4.20 kW
- Heavy duty cast iron pan stands
- Automatic electronic ignition
- Safety valves







## Main Oven



### Upper and lower element only:

A traditional cooking method best suited for single items located in the centre of the oven. The top of the oven will always be hottest. Ideal for roast, fruit cakes, bread etc.



### Circulaire:

The combination of the fan and circular element around it gives a hot air cooking method. This provides many benefits including no preheat if cook time is more than 20 minutes, no flavour transfer when cooking different foods at the same time, less energy, and shorter cook times. Good for all types of food.



### Circulaire with lower element :

The addition of the lower element adds extra heat at the base for food which requires extra cooking..



### Half grill:

For rapid cooking and browning of foods. Best results can be obtained by using the top shelf for small items, the lower shelves for larger ones, such as chops or sausages. For half grill heat is generated only at the centre of the element, so is ideal for smaller quantities.

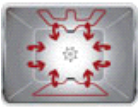

### Fan with upper and lower elements:

The elements combined with the fan aim to provide more uniform heat, a similar method to conventional cooking, so pre-heat is required. Most suitable for items requiring slow cooking methods.



### FAN WITH LOWER ELEMENT/ CIRCOGAS:

In electric ovens this combination completes cooking more quickly of foods that are ready on the surface, but that require more cooking inside, without further browning. In gas ovens the fan distributes the heat quickly and evenly throughout the oven cavity, avoiding flavour transfer when cooking a number of different dishes at the same time.



### Fan with grill element:

The fan reduces the fierce heat from the grill, providing an excellent method of grilling various foods, chops, steaks, sausages etc. giving even browning and heat distribution, without drying out the food. The top two levels recommended for use, and the lower part of the oven can be used to keep items warm at the same time, an excellent facility when cooking a grilled breakfast. Half grill (centre portion only) is ideal for small quantities of food.



### Snowflake:

With the switch on this symbol, no heating is possible even if the thermostat is turned.



**Vapor clean**  
Vapor clean

## Auxiliary Oven

**Upper and lower element only:**

A traditional cooking method best suited for single items located in the centre of the oven. The top of the oven will always be hottest. Ideal for roast, fruit cakes, bread etc.

---

**Half grill:**

For rapid cooking and browning of foods. Best results can be obtained by using the top shelf for small items, the lower shelves for larger ones, such as chops or sausages. For half grill heat is generated only at the centre of the element, so is ideal for smaller quantities.

---

**Grill element:**

For rapid cooking and browning of foods. Best results can be obtained by using the top shelf for small items, the lower shelves for larger ones, such as chops or sausages. For half grill heat is generated only at the centre of the element, so is ideal for smaller quantities.

---

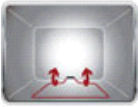
**Lower heating element only:**

Ideal for foods that require extra base temperature without browning, e.g. pastry dishes, pizza. Also suitable for slow cooking of stews and casseroles.

---

**FAN WITH LOWER ELEMENT/ CIRCOGAS:**

In electric ovens this combination completes cooking more quickly of foods that are ready on the surface, but that require more cooking inside, without further browning. In gas ovens the fan distributes the heat quickly and evenly throughout the oven cavity, avoiding flavour transfer when cooking a number of different dishes at the same time.

---

**Rotisserie with half grill:**

These symbols allow use of the rotisserie with half grill.

---

**Top element only:**

Useful for browning the tops of dishes such as lasagne and potato or cheese topped recipes.

---



## A2-81

Opera range  
100 cm  
stainless steel  
hob type: cookers with gas hob  
oven type: electric  
energy rating A+B

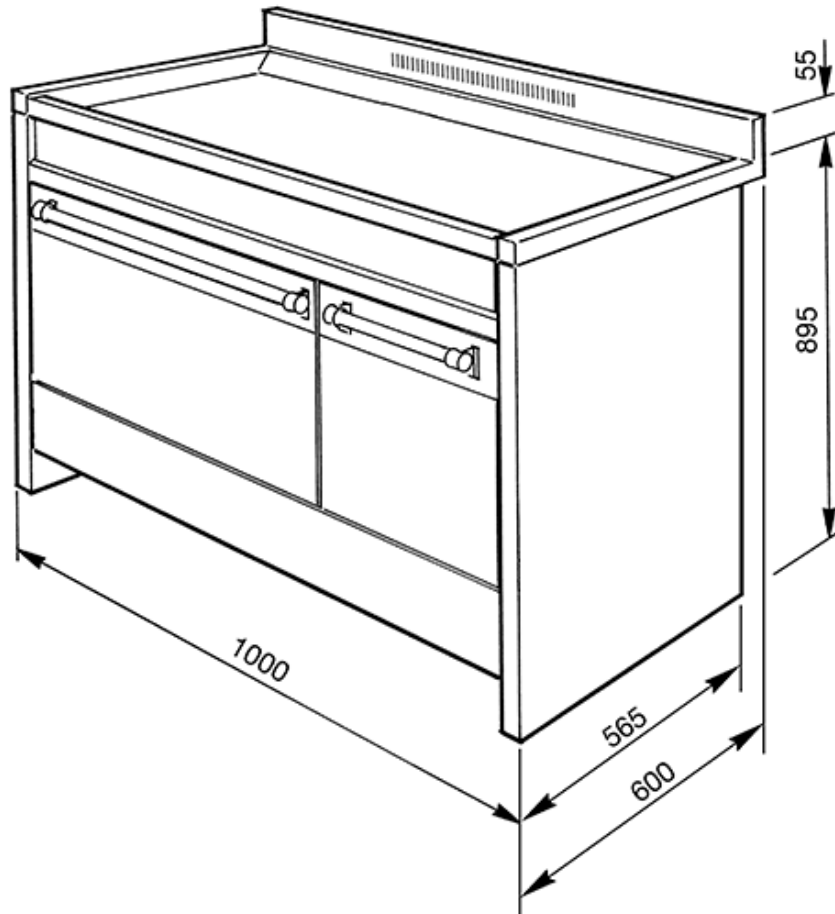

Smeg (UK) Ltd  
The Magna Building, Wyndyke Furlong, Abingdon  
OX14 1DZ  
Tel. +44 (0)844 557 9907  
Fax +44 (0)844 557 9337