

# A2-81

Cooker size	100x60 cm
N. of cavities with energy label	2
Heat source first cavity	Electric
Hob type	Gas
Type of main oven	Thermo-ventilated
Type of second oven	Static
Cleaning system main oven	Catalytic
EAN code	8017709256746
Energy efficiency class	A
Energy efficiency class, second cavity	B



## Aesthetics



<b>Aesthetics</b>	Classic	<b>Controls colour</b>	Stainless steel
<b>Series</b>	Opera	<b>Display</b>	Touch
<b>Colour</b>	Stainless steel	<b>No. of controls</b>	10
<b>Design</b>	Professional	<b>Serigraphy colour</b>	Black
<b>Door</b>	With 2 horizontal strips	<b>Handle</b>	Smeg Classic
<b>Upstand</b>	Yes	<b>Handle Colour</b>	Brushed stainless steel
<b>Type of pan stands</b>	Cast Iron	<b>Glass type</b>	dark grey
<b>Hob colour</b>	Stainless steel	<b>Storage compartment</b>	Drawer
<b>Command panel finish</b>	Finger friendly stainless steel	<b>Logo</b>	Assembled st/steel
<b>Control knobs</b>	Smeg Classic	<b>Logo position</b>	Facia below the oven

## Programme / Functions

No. of cooking functions 8  
Traditional cooking functions



Static



Fan assisted



Circulaire



ECO



Small grill



Large grill



Fan grill (small)



Fan assisted base

## Cleaning functions

Catalytic

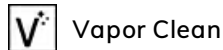

## Programs / Functions Auxiliary Oven

Cooking functions cavity 2 6

Traditional cooking functions, cavity 2



Static



Small grill



Large grill



Bottom



Rotisserie + grill



Roof

## Hob technical features

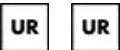

Total no. of cook zones 6

Front left - Gas - Semi Rapid - 1.80 kW

Rear left - Gas - 2UR (dual) - 4.20 kW

Front centre - Gas - AUX - 1.00 kW

Rear centre - Gas - Semi Rapid - 1.80 kW

Front right - Gas - 2UR (dual) - 4.20 kW

Rear right - Gas - Rapid - 3.00 kW

Type of gas burners Standard

Gas safety valves Yes

Automatic electronic ignition Yes

Burner caps

Matt black enamelled

## Main Oven Technical Features



No. of lights	1
Fan number	1
Net volume of the cavity	61 litres
Gross volume, 1st cavity	70 l
Cavity material	Easy clean enamel
Shelf positions	4
Type of shelves	Metal racks
Light type	Halogen
Light power	40 W
Cooking time setting	Start and Stop
Light when oven door is open	Yes
Door opening	Flap down
Removable door	Yes

Total no. of door glasses	3
No. of thermo-reflective door glasses	2
Safety Thermostat	Yes
Cooling system	Tangential
Usable cavity space dimensions (HxWxD)	316x460x412 mm
Temperature control	Electro-mechanical
Lower heating element power	1200 W
Upper heating element - Power	1000 W
Grill element	1700 W
Large grill - Power	2700 W
Circular heating element - Power	2000 W
Grill type	Electric
Tilting grill	Yes

## Options Main Oven

Timer	Yes	Minimum Temperature	50 °C
End of cooking acoustic alarm	Yes	Maximum temperature	250 °C

## Second Oven Technical Features



Net volume of the second cavity	35 litres	No. total door glasses	3
Gross volume, 2nd cavity	36 l	No. thermo-reflective door glasses	2
Cavity material	Easy clean enamel	Safety Thermostat	Yes
Shelf positions	4	Cooling system	Tangential
Type of shelves	Metal racks	Usable cavity space dimensions (HxWxD)	310x255x417 mm
Roof Liner	Yes	Temperature control	Electro-mechanical
No. of lights	1	Lower heating element - power	750 W
Light type	Incandescent	Upper heating element - Power	650 W
Light power	25 W	Grill element - power	1400 W
Light when oven door is open	Yes	Large grill - Power	2050 W
Door opening	Flap down	Grill type	Electric
Removable door	Yes		

## Options Auxiliary Oven

Minimum Temperature	50 °C	Maximum temperature	250 °C
---------------------	-------	---------------------	--------

## Accessories included for Main Oven & Hob

Top oven chrome shelf with back stop	1	40mm deep tray	1
Grill mesh	1	Catalytic panels	3
20mm deep tray	1		

## Accessories included for Secondary Oven

Rotisserie	1	Grill mesh	1
Chrome shelf with back and side stop	1	Wide baking tray	1

## Electrical Connection

Nominal power	5300 W	Frequency	50/60 Hz
---------------	--------	-----------	----------

---

<b>Current</b>	23 A	<b>Power supply cable length</b>	200 cm
<b>Voltage</b>	220-240 V	<b>Terminal block</b>	3 poles

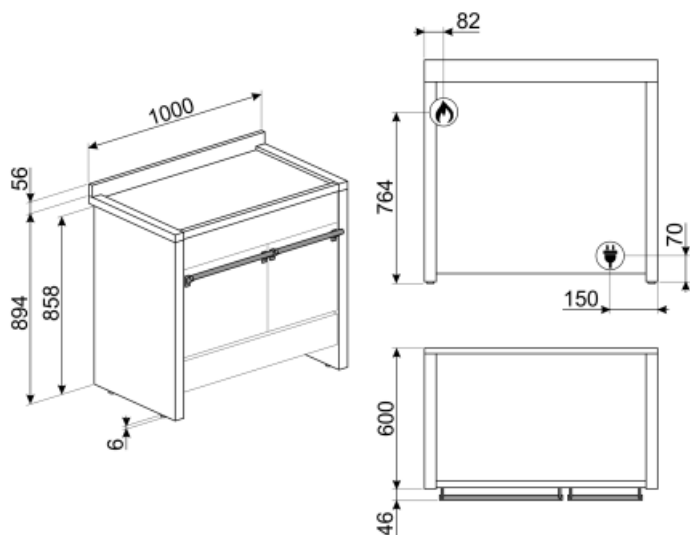

## Not included accessories

### KIT1CSP20

Splashback 100x75, for pyrolytic A2 cookers

### GTP

\*\*Partially extractable telescopic guides (1 level)\*\* Extraction: 300 mm Material: Stainless steel AISI 430 polished



### KIT1A2PY-81

Splashback, 90x75 cm, stainless steel, suitable for pyrolytic Opera A2



### PPR2

Refractory pizza stone without handles. Squared shaped stone: L42 x H1,8 x D37,5 cm. Suitable also for gas ovens, to be put on the griddle.



### KIT1A2-6

Splashback, 100x75 cm, stainless steel, suitable for Opera A2 cookers



### BN620-1

Enamelled tray, 20mm deep



### GTT

\*\*Totally extractable telescopic guides (1 level)\*\* Extraction: 433 mm Material: Stainless steel AISI 430 polished



### SMOLD

Set of 7 silicone moulds for ice creams, ice lollies, pralines, ice cubes or to portion food. Usable from -60°C to +230°C

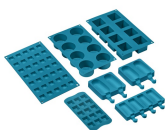

### SFLK1

Child lock



### PRTX

Refractory pizza stone with handles. D=35cm Not suitable for microwave ovens. Suitable for gas ovens, to be put on the griddle.



### KIT2A2-8

Plinth, 100 cm, stainless steel suitable for A2-8 Opera cookers



### KIT3-6

Height extension kit (950 mm), stainless steel, for Opera cookers



### GTA-6

Telescopic shelf support set with 3 levels. length: 369 mm. 2 totally extractable telescopic guides, 431 mm. 1 partially extractable telescopic guides, 177 mm (bottom level). Material: stainless steel AISI 430 polish.



### PALPZ

Pizza shovel with fold away handle width: 315mm length : 325mm



























### BN640

Enamelled tray, 40mm deep



## Symbols glossary

- A** A: Product drying performance, measured from A+++ to D / G depending on the product family
-  Heavy duty cast iron pan stands: for maximum stability and strength.
-  Triple glazed doors: Number of glazed doors.
-  Fingerprint proof stainless steel: Fingerprint proof stainless steel keeps stainless steel looking as good as new.
-  Fan with upper and lower elements: The elements combined with the fan aim to provide more uniform heat, a similar method to conventional cooking, so pre-heat is required. Most suitable for items requiring slow cooking methods.
-  Lower heating element only: This function is ideal for foods that require extra base temperature without browning, e.g. pastry dishes, pizza. Also suitable for slow cooking of stews and casseroles.
-  ECO: The combination of the grill, fan and lower element is particularly suitable for cooking small quantities of food.
-  Grill element: Using of grill gives excellent results when cooking meat of medium and small portions, especially when combined with a rotisserie (where possible). Also ideal for cooking sausages and bacon.
- B** B: Product energy rating, measured from A+++ to D / G depending on the product family.
-  Air cooling system: to ensure a safe surface temperatures.
-  Enamel interior: The enamel interior of all Smeg ovens have a special antacid lining which helps keep the interior clean by reducing the amount of cooking grease adhering to it.
-  Circogas: In gas ovens the fan distributes the heat quickly and evenly throughout the oven cavity, avoiding flavour transfer when cooking a number of different dishes at the same time. In electric ovens this combination completes cooking more quickly of foods that are ready on the surface, but that require more cooking inside, without further browning.
-  Upper and lower element only: a traditional cooking method best suited for single items located in the centre of the oven. the top pf the oven will always be hottest. Ideal for roast, fruit cakes, bread etc.
-  Circulaire: The combination of the fan and circular element around it gives a hot air cooking method. This provides many benefits including no preheat if cook time is more than 20 minutes, no flavour transfer when cooking different foods at the same time, less energy, and shorter cook times. Good for all types of food.
-  Fan with grill element: The fan reduces the fierce heat from the grill, providing an excellent method of grilling various foods, chops, steaks, sausages etc. giving even browning and heat distribution, without drying out the food. The top two levels recommended for use, and the lower part of the oven can be used to keep items warm at the same time, an excellent facility when cooking a grilled breakfast. Half grill (centre portion only) is ideal for small quantities of food.
-  Half grill: For rapid cooking and browning of foods. Best results can be obtained by using the top shelf for small items, the lower shelves for larger ones, such as chops or sausages. For half grill heat is generated only at the centre of the element, so is ideal for smaller quantities.

- 
- |   |   |
|---|---|
|  <p>Rotisserie with half grill: These symbols allow use of the rotisserie with half grill.</p>  |  <p>Top element only: This is used from above only, and is ideal for foods that are finished off with golden topping but do not require the full heat from the grill. Dishes such as Lasagne, potato topped foods, and cheese topped recipes benefit from this mode.</p> |
|  <p>Side lights: Two opposing side lights increase visibility inside the oven.</p>  |  <p>Removable roof liner: This is a perfect solution that protects the upper part of the cavity of the oven from pollution. Easy to remove for cleaning, it can be washed in the dishwasher.</p>   |
|  <p>The oven cavity has 4 different cooking levels.</p>   |  <p>Electronic control: Allows you to maintain temperature inside the oven with the precision 2-3 ° C. This enables to cook meals that are very sensitive to temperature changes, such as cakes, souffles, puddings.</p>   |
|  <p>Tilting grill: the tilting grill can be easily unhooked to move the heating element and clean the roof of the appliance in one simple step.</p> |  <p>Ultra rapid burners: Powerful ultra rapid burners offer up to 5kw of power.</p>  |
|  <p>Vapor Clean: a simple cleaning function using steam to loosen deposits in the oven cavity.</p>  |  <p>The capacity indicates the amount of usable space in the oven cavity in litres.</p>  |
|  <p>The capacity indicates the amount of usable space in the oven cavity in litres.</p>   |   |