

## A4-81 New product

120cm "Opera" Dual cavity Cooker  
with Gas hob and Electric griddle, Stainless Steel  
Energy rating AB

EAN13: 8017709256807

### OVEN ONE



- 9 functions
- Oven capacity: gross - 70 litres, net - 61 litres
- Usable cavity space dimensions (HxWxD): 316x444x425mm

### Touch timer display

### Eclipse black glass

- Air cooling system
- Closed door grilling
- Triple glazed removable doors
- Easy clean enamel interior
- 4 cooking levels, Metal side supports

### Vapor clean function

### OVEN TWO



- 6 functions
- Oven capacity: gross - 70 litres, net - 55 litres
- Usable cavity space dimensions (HxWxD): 290x444x425mm
- Air cooling system
- Closed door grilling
- Triple glazed removable doors
- Special pizza cooking function
- Easy clean enamel interior
- 4 cooking levels, Metal side supports
- Storage drawer beneath the ovens

### HOB



- 6 burners + griddle
- Rear left: 1.8 kW
- Front left: Ultra rapid 4.2 kW
- Rear centre: Rapid 3.0 kW
- Front centre: 1.0 kW
- Electric griddle: 1.6 kW with Teflon coated plate
- Rear right: Fishburner 1.9 kW
- Front right: 1.0 kW
- Heavy duty cast iron pan stands
- Automatic electronic ignition
- Safety valves
- Adaptable for LPG



#### STANDARD ACCESSORIES:

Oven one:

- 1 x Extra deep tray (40mm deep)
- 1 x Roasting/grill pan (20mm deep)
- 1 x Grill mesh
- 2 x Chrome shelves
- Stay clean liners
- Telescopic shelves (Partical extraction)

Oven two:

- 1 x Extra deep tray (40mm deep)
- 1 x Chrome shelf
- 1 x Grill mesh
- Stay clean liners
- Pizza Accessories: Refractory stone + cover + shovel

#### Nominal power: 7.5kW

- Supply can vary depending on usage, please consult a qualified electrician for ampere requirement

Please note that this model supersedes the A4-8

## Functions

---



Main Oven



Auxiliary Oven

## Options

---

- **KIT1A3-6** - St/steel splash back
- **PRTX** - Pizza stone with handles
- **PALPZ** - Folding Pizza Shovel
- **WOKGHU** - Wok Support
- **GO120** - Cast Iron Open Griddle for Barbecue
- **GC120** - Cast Iron Ribbed Griddle
- **TPKX** - Teppanyaki Grill Plate



## Main Oven



### Circulaire:

The combination of the fan and circular element around it gives a hot air cooking method. This provides many benefits including no preheat if cook time is more than 20 minutes, no flavour transfer when cooking different foods at the same time, less energy, and shorter cook times. Good for all types of food.



### Circulaire with lower element :

The addition of the lower element adds extra heat at the base for food which requires extra cooking..

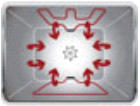

### Fan with upper and lower elements:

The elements combined with the fan aim to provide more uniform heat, a similar method to conventional cooking, so pre-heat is required. Most suitable for items requiring slow cooking methods.



### FAN WITH LOWER ELEMENT/ CIRCOGAS:

In electric ovens this combination completes cooking more quickly of foods that are ready on the surface, but that require more cooking inside, without further browning. In gas ovens the fan distributes the heat quickly and evenly throughout the oven cavity, avoiding flavour transfer when cooking a number of different dishes at the same time.



### Upper and lower element only:

A traditional cooking method best suited for single items located in the centre of the oven. The top of the oven will always be hottest. Ideal for roast, fruit cakes, bread etc.



### Grill element:

For rapid cooking and browning of foods. Best results can be obtained by using the top shelf for small items, the lower shelves for larger ones, such as chops or sausages. For half grill heat is generated only at the centre of the element, so is ideal for smaller quantities.



### Fan with grill element:

The fan reduces the fierce heat from the grill, providing an excellent method of grilling various foods, chops, steaks, sausages etc. giving even browning and heat distribution, without drying out the food. The top two levels recommended for use, and the lower part of the oven can be used to keep items warm at the same time, an excellent facility when cooking a grilled breakfast. Half grill (centre portion only) is ideal for small quantities of food.



### Snowflake:

With the switch on this symbol, no heating is possible even if the thermostat is turned.



**Vapor clean**  
Vapor clean

## Auxiliary Oven

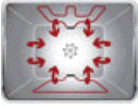
**Fan with upper and lower elements:**

The elements combined with the fan aim to provide more uniform heat, a similar method to conventional cooking, so pre-heat is required. Most suitable for items requiring slow cooking methods.

---

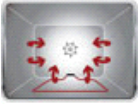
**FAN WITH LOWER ELEMENT/ CIRCOGAS:**

In electric ovens this combination completes cooking more quickly of foods that are ready on the surface, but that require more cooking inside, without further browning. In gas ovens the fan distributes the heat quickly and evenly throughout the oven cavity, avoiding flavour transfer when cooking a number of different dishes at the same time.

---

**Upper and lower element only:**

A traditional cooking method best suited for single items located in the centre of the oven. The top of the oven will always be hottest. Ideal for roast, fruit cakes, bread etc.

---

**Grill element:**

For rapid cooking and browning of foods. Best results can be obtained by using the top shelf for small items, the lower shelves for larger ones, such as chops or sausages. For half grill heat is generated only at the centre of the element, so is ideal for smaller quantities.

---

**Fan with grill element:**

The fan reduces the fierce heat from the grill, providing an excellent method of grilling various foods, chops, steaks, sausages etc. giving even browning and heat distribution, without drying out the food. The top two levels recommended for use, and the lower part of the oven can be used to keep items warm at the same time, an excellent facility when cooking a grilled breakfast. Half grill (centre portion only) is ideal for small quantities of food.

---

**Pizza function:**

The simultaneous operation of these three elements ensures an optimum cooking facility, ideal not only for pizza but also for cookies, quiches and flans.

---



## A4-81

Opera range  
120 cm  
stainless steel  
hob type: gas + griddle  
oven type: electric  
energy rating A+B

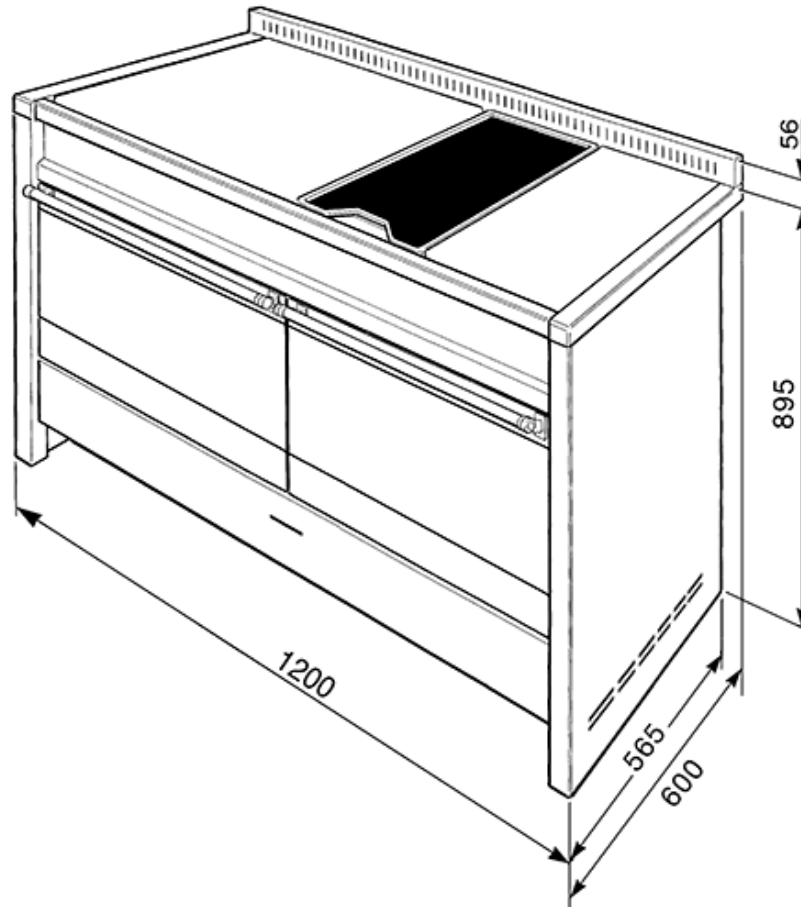

Smeg (UK) Ltd  
The Magna Building, Wyndyke Furlong, Abingdon  
OX14 1DZ  
Tel. +44 (0)844 557 9907  
Fax +44 (0)844 557 9337