

A5-81

Cooker size	150x60 cm
N. of cavities with energy label	2
Heat source first cavity	Electric
Hob type	Gas
Type of main oven	Thermo-ventilated
Type of second oven	Thermo-ventilated
EAN code	8017709260774
Energy efficiency class	A
Energy efficiency class, second cavity	A



Aesthetics



Aesthetics	Classic	Controls colour	Stainless steel
Series	Opera	Display	Touch
Colour	Stainless steel	No. of controls	13
Design	Professional	Serigraphy colour	Black
Door	With 2 horizontal strips	Handle	Smeg Classic
Upstand	Yes	Handle Colour	Brushed stainless steel
Type of pan stands	Cast Iron	Glass type	dark grey
Hob colour	Stainless steel	Storage compartment	Drawer
Command panel finish	Finger friendly stainless steel	Logo	Assembled st/steel
Control knobs	Smeg Classic	Logo position	Facia below the oven

Programme / Functions

No. of cooking functions	8
--------------------------	---

Traditional cooking functions



Static



Fan assisted



Circulaire



Turbo (circulaire + bottom + upper + fan)



ECO



Large grill



Fan grill (large)



Fan assisted base

Programs / Functions Auxiliary Oven

Cooking functions cavity 2 8

Traditional cooking functions, cavity 2



Static



Fan assisted



Circulaire



Large grill



Fan grill (large)



Fan-assisted bottom



Circulaire + Bottom + Fan



Pizza

Cleaning functions cavity 2 catalytic

Hob technical features



Total no. of cook zones 7

Front left - Gas - 2UR (dual) - 4.20 kW

Rear left - Gas - Semi Rapid - 1.80 kW

Front centre - Gas - AUX - 1.00 kW

Rear centre - Gas - Rapid - 3.00 kW

Front right - Gas - AUX - 1.00 kW

Rear right - Gas - Fish burner - 1.90 kW

Right - Gas - 2UR (dual) - 5.00 kW

Central - BBQ - 1.60 (BBQ) kW

Type of gas burners Standard

Burner caps

Matt black enamelled

Automatic electronic ignition Yes

Automatic switch off when overflow

Yes

Gas safety valves Yes

Main Oven Technical Features

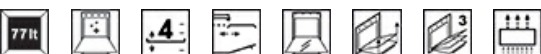

No. of lights

2

Full glass inner door

Yes

Fan number	1	Removable inner door	Yes
Net volume of the cavity	77 litres	Total no. of door glasses	3
Gross volume, 1st cavity	90 l	No. of thermo-reflective door glasses	2
Cavity material	Easy clean enamel	Safety Thermostat	Yes
Shelf positions	4	Cooling system	Tangential
Type of shelves	Metal racks	Usable cavity space dimensions (HxWxD)	305X613X405 mm
Roof Liner	Yes	Temperature control	Electro-mechanical
Light type	Incandescent	Lower heating element power	1750 W
Light power	25 W	Upper heating element - Power	1050 W
Cooking time setting	Start and Stop	Grill element	2800 W
Light when oven door is open	Yes	Circular heating element - Power	2500 W
Door opening	Flap down	Grill type	Electric
Removable door	Yes		

Options Main Oven

Timer	Yes	Minimum Temperature	50 °C
End of cooking acoustic alarm	Yes	Maximum temperature	250 °C

Second Oven Technical Features

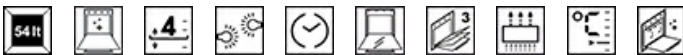

Net volume of the second cavity	54 litres	Removable inner door	Yes
Gross volume, 2nd cavity	70 l	No. total door glasses	3
Cavity material	Easy clean enamel	No. thermo-reflective door glasses	2
Shelf positions	4	Safety Thermostat	Yes
Type of shelves	Metal racks	Cooling system	Tangential
No. of lights	1	Usable cavity space dimensions (HxWxD)	290x444x425 mm
Light type	Halogen	Temperature control	Electro-mechanical
Light power	40 W	Lower heating element - power	1100 W
Cooking time setting	Stop	Upper heating element - Power	1000 W
Light when oven door is open	Yes	Grill element - power	1700 W
Door opening	Flap down	Circular heating element - Power	2000 W
Removable door	Yes	Grill type	Electric
Full glass inner door	Yes	Tilting grill	Yes

Options Auxiliary Oven

Timer	Yes	Minimum Temperature	50 °C
--------------	-----	----------------------------	-------

End of cooking acoustic alarm Yes

Maximum temperature 280 °C

Accessories included for Main Oven & Hob

Top oven chrome shelf with back stop 2

Wide baking tray 2

Accessories included for Secondary Oven

Chrome shelf with back and side stop 1

Catalytic panels 3

Grill mesh 1

Pizza Accessories Refractory stone + cover + shovel

40mm deep tray 1

Electrical Connection

Nominal power 7700 W

Frequency 50/60 Hz

Current 34 A

Power supply cable length 150 cm

Voltage 220-240 V

Terminal block

Voltage 2 (V) 380-415 V

5 poles

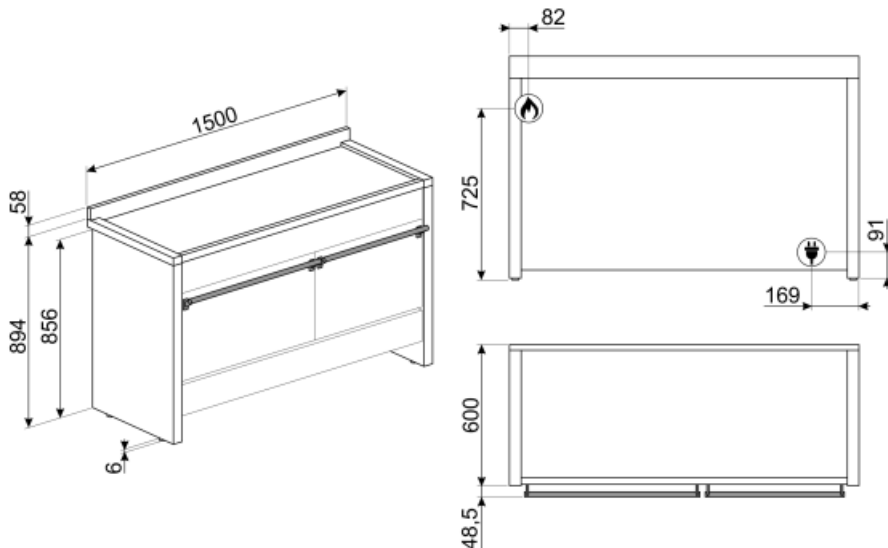

Not included accessories



PAL2

Paletta pizza larga con doppio manico.



SFLK1

Child lock



PRTX

Refractory pizza stone with handles. D=35cm Not suitable for microwave ovens. Suitable for gas ovens, to be put on the griddle.



PPR2

Refractory pizza stone without handles. Squared shaped stone: L42 x H1,8 x D37,5 cm. Suitable also for gas ovens, to be put on the griddle.



TPKX

Teppanyaki stainless steel



GC120

Cast iron grill plate suitable for A3/A4/A5 cookers

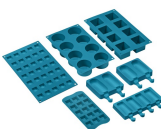

SMOLD

Set of 7 silicone moulds for ice creams, ice lollies, pralines, ice cubes or to portion food. Usable from -60°C to +230°C



KIT2A5-5

Plinth, 150 cm, stainless steel suitable for A5 Opera cookers



GTP

Partially extractable telescopic guides (1 level) Extraction: 300 mm Material: Stainless steel AISI 430 polished



PPR9

Refractory pizza stone without handles. Squared shaped stone: L64xH2,3xP37,5 cm Suitable also for gas ovens, to be put on the griddle.



KIT3-6

Height extension kit (950 mm), stainless steel, for Opera cookers



GTA-6

Telescopic shelf support set with 3 levels. length: 369 mm. 2 totally extractable telescopic guides, 431 mm. 1 partially extractable telescopic guides, 177 mm (bottom level). Material: stainless steel AISI 430 polish.



PALPZ



















Pizza shovel with fold away handle width: 315mm length : 325mm













GTT

Totally extractable telescopic guides (1 level) Extraction: 433 mm Material: Stainless steel AISI 430 polished

Symbols glossary

 <p>A: Product drying performance, measured from A+++ to D / G depending on the product family</p>	 <p>Heavy duty cast iron pan stands: for maximum stability and strength.</p>
 <p>Air cooling system: to ensure a safe surface temperatures.</p>	 <p>Triple glazed doors: Number of glazed doors.</p>
 <p>Enamel interior: The enamel interior of all Smeg ovens have a special antacid lining which helps keep the interior clean by reducing the amount of cooking grease adhering to it.</p>	 <p>Fingerprint proof stainless steel: Fingerprint proof stainless steel keeps stainless steel looking as good as new.</p>
 <p>Circogas: In gas ovens the fan distributes the heat quickly and evenly throughout the oven cavity, avoiding flavour transfer when cooking a number of different dishes at the same time. In electric ovens this combination completes cooking more quickly of foods that are ready on the surface, but that require more cooking inside, without further browning.</p>	 <p>Fan with upper and lower elements: The elements combined with the fan aim to provide more uniform heat, a similar method to conventional cooking, so pre-heat is required. Most suitable for items requiring slow cooking methods.</p>
 <p>Upper and lower element only: a traditional cooking method best suited for single items located in the centre of the oven. the top pf the oven will always be hottest. Ideal for roast, fruit cakes, bread etc.</p>	 <p>Circulaire with lower element: The addition of the lower element adds extra heat at the base for food which requires extra cooking.</p>
 <p>Circulaire: The combination of the fan and circular element around it gives a hot air cooking method. This provides many benefits including no preheat if cook time is more than 20 minutes, no flavour transfer when cooking different foods at the same time, less energy, and shorter cook times. Good for all types of food.</p>	 <p>ECO: The combination of the grill, fan and lower element is particularly suitable for cooking small quantities of food.</p>
 <p>Grill element: Using of grill gives excellent results when cooking meat of medium and small portions, especially when combined with a rotisserie (where possible). Also ideal for cooking sausages and bacon.</p>	 <p>Fan with grill element: The fan reduces the fierce heat from the grill, providing an excellent method of grilling various foods, chops, steaks, sausages etc. giving even browning and heat distribution, without drying out the food. The top two levels recommended for use, and the lower part of the oven can be used to keep items warm at the same time, an excellent facility when cooking a grilled breakfast. Half grill (centre portion only) is ideal for small quantities of food.</p>
 <p>Pizza function: The simultaneous operation of three elements ensures an optimum cooking facility when used with the Smeg pizza stone.</p>	 <p>Circulaire with upper and lower elements: The use of the fan with both elements allows food to be cooked quickly and effectively, ideal for large joints that require thorough cooking. It offers a similar result to rotisserie, moving the heat around the food, instead of moving the food itself, enabling any size or shape to be cooked.</p>
 <p>All glass inner door: All glass inner door, a single flat surface which is simple to keep clean.</p>	 <p>The inner door glass: can be removed with a few quick movements for cleaning.</p>

-
- | | |
|--|--|
|  <p>Side lights: Two opposing side lights increase visibility inside the oven.</p> |  <p>Overfill protection: The special overfill protection shuts down the stove in the presence of overflow of liquids.</p> |
|  <p>Removable roof liner: This is a perfect solution that protects the upper part of the cavity of the oven from pollution. Easy to remove for cleaning, it can be washed in the dishwasher.</p> |  <p>The oven cavity has 4 different cooking levels.</p> |
|  <p>Electronic control: Allows you to maintain temperature inside the oven with the precision 2-3 ° C. This enables to cook meals that are very sensitive to temperature changes, such as cakes, souffles, puddings.</p> |  <p>Tilting grill: the tilting grill can be easily unhooked to move the heating element and clean the roof of the appliance in one simple step.</p> |
|  <p>Timer: All ceramic hobs have a timer which automatically ends cooking after a preset time.</p> |  <p>Ultra rapid burners: Powerful ultra rapid burners offer up to 5kw of power.</p> |
|  <p>The capacity indicates the amount of usable space in the oven cavity in litres.</p> |  <p>The capacity indicates the amount of usable space in the oven cavity in litres.</p> |