

CPF120IGMPBL New product

Portofino

120cm "Portofino" Dual Cavity Cooker with Mixed Fuel Hob, Black
Energy rating AA

EAN13: 8017709286064

Special promotion on this model* 5 year guarantee on parts and labour if purchased by 31st December 2020. Models included are CPF9G* & CPF9I* CPF120IGMP*. Terms and conditions apply. Offer available from selected displaying retailers only. [For full terms and conditions please click here](#)



MAIN OVEN



- 10 functions
- Oven capacity: gross - 79 litres, net – 70 litres
- Touch timer display
- Usable cavity space dimensions (HxWxD): 360X460X425 mm
- Air cooling system
- Closed door grilling
- Quadruple glazed door
- Easy clean enamel interior
- 5 cooking levels, metal side supports
- Removable inner door
- Soft close door
- 2 x 40W halogen lights

Pyrolytic cleaning function

AUXILIARY OVEN



- 9 functions
- Oven capacity: gross – 79 litres, net – 63 litres
- Touch timer display
- Usable cavity space dimensions (HxWxD): 360X460X425 mm
- Air cooling system
- Closed door grilling
- Triple glazed door
- Easy clean enamel interior
- 5 cooking levels, metal side supports
- Removable inner door
- Soft close door

Direct steam technology

Vapor clean function

- Storage compartments beneath the ovens

HOB



3 burners + Griddle + Induction

- Left: Ultra rapid 4.20kW
- Front centre: 1.80kW
- Rear centre: 3.00kW
- Electric griddle: 1.60kW
- Front right induction: 210mm, 2.1kW (booster 2.30kW)
- Rear right induction: 210mm, 1.60kW (booster 1.85kW)
- Heavy duty cast iron pan stands
- Automatic electronic ignition
- Safety valves
- Adaptable for LPG
- Automatic safety cut-out
- Multizone

STANDARD ACCESSORIES:

2 x roasting/grill pans (20mm deep)
 2 x telescopic guide set - partial extraction
 2 x chrome shelves
 2 x extra deep trays (40mm deep)
 2 x grill mesh
 1 x meat probe

- Nominal power: 10.90kW
- Supply can vary depending on usage, please consult a qualified electrician for ampere requirement

Functions



Options

- **KIT1CPF120X** - 120x60cm Portofino cooker splashback, St/steel

Versions

- **CPF120IGMPT** - 120cm 'Portofino' dual cavity cooker with mixed fuel hob, Turquoise
- **KPF12BL** - 120cm Portofino chimney hood, Black
- **KPF12RD** - 120cm Portofino chimney hood, Red
- **CPF120IGMPBL** - 120cm 'Portofino' dual cavity cooker with mixed fuel hob, Black
- **CPF120IGMPWH** - 120cm 'Portofino' dual cavity cooker with mixed fuel hob, White
- **KPF12T** - 120cm Portofino chimney hood, Turquoise
- **KPF12WH** - 120cm Portofino chimney hood, White
- **CPF120IGMPX** - 120cm 'Portofino' dual cavity cooker with mixed fuel hob, St/steel
- **CPF120IGMPR** - 120cm 'Portofino' dual cavity cooker with mixed fuel hob, Red
- **KPF12X** - 120cm Portofino chimney hood, St/Steel



Main Oven



Circulaire with upper and lower elements:

The use of the fan with both elements allows food to be cooked quickly and effectively, ideal for large joints that require thorough cooking. It offers a similar result to rotisserie, moving the heat around the food, instead of moving the food itself, enabling any size or shape to be cooked.



Circulaire:

The combination of the fan and circular element around it gives a hot air cooking method. This provides many benefits including no preheat if cook time is more than 20 minutes, no flavour transfer when cooking different foods at the same time, less energy, and shorter cook times. Good for all types of food.

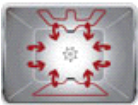

Fan with upper and lower elements:

The elements combined with the fan aim to provide more uniform heat, a similar method to conventional cooking, so pre-heat is required. Most suitable for items requiring slow cooking methods.



Fan with grill element:

The fan reduces the fierce heat from the grill, providing an excellent method of grilling various foods, chops, steaks, sausages etc. giving even browning and heat distribution, without drying out the food. The top two levels recommended for use, and the lower part of the oven can be used to keep items warm at the same time, an excellent facility when cooking a grilled breakfast. Half grill (centre portion only) is ideal for small quantities of food.



Grill element:

For rapid cooking and browning of foods. Best results can be obtained by using the top shelf for small items, the lower shelves for larger ones, such as chops or sausages. For half grill heat is generated only at the centre of the element, so is ideal for smaller quantities.



FAN WITH LOWER ELEMENT/ CIRCOGAS:

In electric ovens this combination completes cooking more quickly of foods that are ready on the surface, but that require more cooking inside, without further browning. In gas ovens the fan distributes the heat quickly and evenly throughout the oven cavity, avoiding flavour transfer when cooking a number of different dishes at the same time.



ECO

ECO:

The combination of the grill, fan (if present) and lower element is particularly suitable for cooking small quantities of food.



Upper and lower element only:

A traditional cooking method best suited for single items located in the centre of the oven. The top of the oven will always be hottest. Ideal for roast, fruit cakes, bread etc.



Half grill:

For rapid cooking and browning of foods. Best results can be obtained by using the top shelf for small items, the lower shelves for larger ones, such as chops or sausages. For half grill heat is generated only at the centre of the element, so is ideal for smaller quantities.



Pyrolytic:

 Pyrolytic cleaning at 500°C destroys all the dirt deposits inside the oven. The process can be set from 1.5 hours to 3 hours, depending on the degree of dirt build up.

Auxiliary Oven



Circulaire:

The combination of the fan and circular element around it gives a hot air cooking method. This provides many benefits including no preheat if cook time is more than 20 minutes, no flavour transfer when cooking different foods at the same time, less energy, and shorter cook times. Good for all types of food.

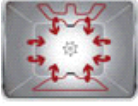

Fan with upper and lower elements:

The elements combined with the fan aim to provide more uniform heat, a similar method to conventional cooking, so pre-heat is required. Most suitable for items requiring slow cooking methods.

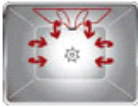

Fan with grill element:

The fan reduces the fierce heat from the grill, providing an excellent method of grilling various foods, chops, steaks, sausages etc. giving even browning and heat distribution, without drying out the food. The top two levels recommended for use, and the lower part of the oven can be used to keep items warm at the same time, an excellent facility when cooking a grilled breakfast. Half grill (centre portion only) is ideal for small quantities of food.



Grill element:

For rapid cooking and browning of foods. Best results can be obtained by using the top shelf for small items, the lower shelves for larger ones, such as chops or sausages. For half grill heat is generated only at the centre of the element, so is ideal for smaller quantities.

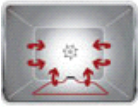

FAN WITH LOWER ELEMENT/ CIRCOGAS:

In electric ovens this combination completes cooking more quickly of foods that are ready on the surface, but that require more cooking inside, without further browning. In gas ovens the fan distributes the heat quickly and evenly throughout the oven cavity, avoiding flavour transfer when cooking a number of different dishes at the same time.



ECO:

The combination of the grill, fan (if present) and lower element is particularly suitable for cooking small quantities of food.



Upper and lower element only:

A traditional cooking method best suited for single items located in the centre of the oven. The top of the oven will always be hottest. Ideal for roast, fruit cakes, bread etc.



Circulaire with steam assist:

Provides extra moisture to food during cooking. Excellent for bread baking. The moisture allows the bread dough to stretch further at the beginning of cooking, creating an aerated and light textured dough. The remaining part of the cooking process allows for the signature crust to form.



Vapor clean

Vapor clean



CPF120IGMPBL

Portofino

Portofino range
120 cm
black

hob type: cookers with gas hob
oven type: electric pyrolytic
energy rating AA

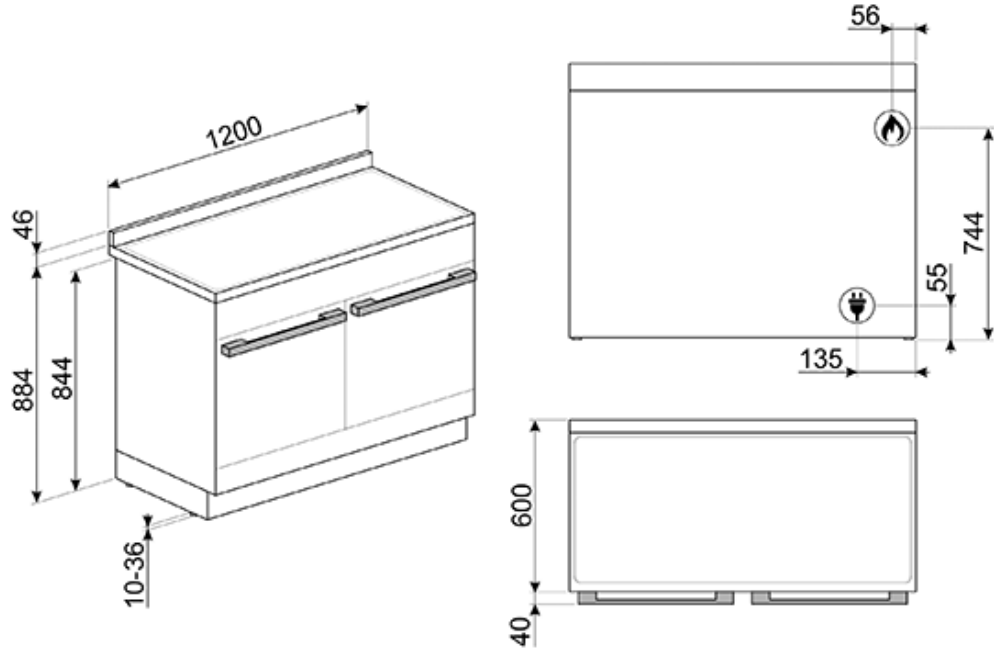

Smeg (UK) Ltd
The Magna Building, Wyndyke Furlong, Abingdon
OX14 1DZ
Tel. +44 (0)844 557 9907
Fax +44 (0)844 557 9337