

CPF9GPR **New product** Available soon

Portofino

PORTOFINO COOKER, 90X60 CM, RED,
GAS HOB, ENERGY RATING A+

EAN13: 8017709229382



[As awarded by The Chicago Athenaeum: Museum of Architecture and Design](#)

Programs / Functions

N. of cooking functions: 10

Cleaning functions: Pyrolysis/Pyrolysis Eco

Automatic programmes: 20

Other functions: Defrost by time, Defrost by weight,
Proving, Sabbath

Aesthetics

Door: With frame

Upstand: yes

Type of pan stands: Cast Iron

Command panel finish: Enamelled metal

Display: LCD

Glass type: Grey

Plinth: Black

Storage compartment: Push pull

Hob technical features

Hob type: Gas

Total no. of cook zones: 6

Gas Type: G20 Natural gas

Gas safety valves

Front left - Gas - 2UR (dual) - 4200 W

Rear left - Gas - AUX - 1000 W

Front centre - Gas - AUX - 1000 W

Rear centre - Gas - Semi Rapid - 1800 W

Front right - Gas - Semi Rapid - 1800 W

Rear right - Gas - Rapid - 3000 W

Main Oven Technical Features

Type of main oven: Thermo-ventilated

Gross capacity (Lt) oven 1: 126

Cavity material: Ever Clean enamel

Usable volume, first cavity: 115 litres

No. of shelves: 5

Type of shelves: Metal racks

No. of lights: 4

Fan number: 3

Cooking time setting: Start and Stop

Removable door

Full glass inner door



Removable inner door
Total no. of door glasses: 4
Safety Thermostat
Cooling system: Tangential
Door Lock During Pyrolysis
Grill element: 1700 W
Grill type: Electric
Large grill - Power: 2900 W
Soft Close: Yes

Options Main Oven

Timer
End of cooking acoustic alarm
Minimum Temperature: 50 °C
Maximum temperature: 260 °C

Accessories included for Main Oven & Hob

Cast iron wok support: 1
Rotisserie: 1
TOP Oven grid with back stop: 2
Grill mesh: 1
40mm deep tray: 2
Telescopic Guide rails, partial Extraction: 1

Electrical Connection

Electrical connection rating: 4000 W
Current: 18 Amp
Voltage: 220-240 V
Voltage 2 (V): 380-415 V
Frequency: 50/60 Hz

Functions



Options

- **KITC9X9-1** - Stainless steel splash back
- **GT1T-2** - Totally extractable telescopic guides, 1 level
- **PALPZ** - Pizza shovel
- **PPR9** - Pizza stone
- **PAL2** - Large Pizza shovel with double handle

Versions

- **CPF9GPAN** - Anthracite
- **CPF9GPBL** - Black
- **CPF9GPOG** - Olive Green
- **CPF9GPOR** - Orange
- **CPF9GPWH** - White
- **CPF9GPX** - Stainless steel
- **CPF9GPYW** - Yellow

SMEG S.p.A.
Via Leonardo da Vinci, 4
42016 Guastalla (RE)
Tel. 0522 821 1



Main Oven

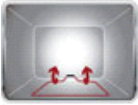

Lower heating element only:

This function is ideal for foods that require extra base temperature without browning, e.g. pastry dishes, pizza. Also suitable for slow cooking of stews and casseroles.



Circogas:

In gas ovens the fan distributes the heat quickly and evenly throughout the oven cavity, avoiding flavour transfer when cooking a number of different dishes at the same time. In electric ovens this combination completes cooking more quickly of foods that are ready on the surface, but that require more cooking inside, without further browning.



Upper and lower element only:

a traditional cooking method best suited for single items located in the centre of the oven. the top of the oven will always be hottest. Ideal for roast, fruit cakes, bread etc.



Fan with upper and lower elements:

The elements combined with the fan aim to provide more uniform heat, a similar method to conventional cooking, so pre-heat is required. Most suitable for items requiring slow cooking methods.



Circulaire:

The combination of the fan and circular element around it gives a hot air cooking method. This provides many benefits including no preheat if cook time is more than 20 minutes, no flavour transfer when cooking different foods at the same time, less energy, and shorter cook times. Good for all types of food.



Circulaire with upper and lower elements:

The use of the fan with both elements allows food to be cooked quickly and effectively, ideal for large joints that require thorough cooking. It offers a similar result to rotisserie, moving the heat around the food, instead of moving the food itself, enabling any size or shape to be cooked.



ECO:

The combination of the grill, fan and lower element is particularly suitable for cooking small quantities of food.



Fan with grill element:

The fan reduces the fierce heat from the grill, providing an excellent method of grilling various foods, chops, steaks, sausages etc. giving even browning and heat distribution, without drying out the food. The top two levels recommended for use, and the lower part of the oven can be used to keep items warm at the same time, an excellent facility when cooking a grilled breakfast. Half grill (centre portion only) is ideal for small quantities of food.



Grill element:

Using of grill gives excellent results when cooking meat of medium and small portions, especially when combined with a rotisserie (where possible). Also ideal for cooking sausages and bacon.



Rotisserie with full grill:

Rotisserie works in combination with a grill that provides an even browning of food.

P Pyrolytic :

Pyrolytic cleaning cycles can be selected as necessary to automatically clean the oven interior.

 **Pyrolytic:** The Eco pyrolytic cleaning function can be selected when the oven has a lighter build up of dirt. This function has a maximum duration of 1.5 hours.



CPF9GPR

Portofino

90 cm
red
hob type: gas
oven type: electric
energy rating A+

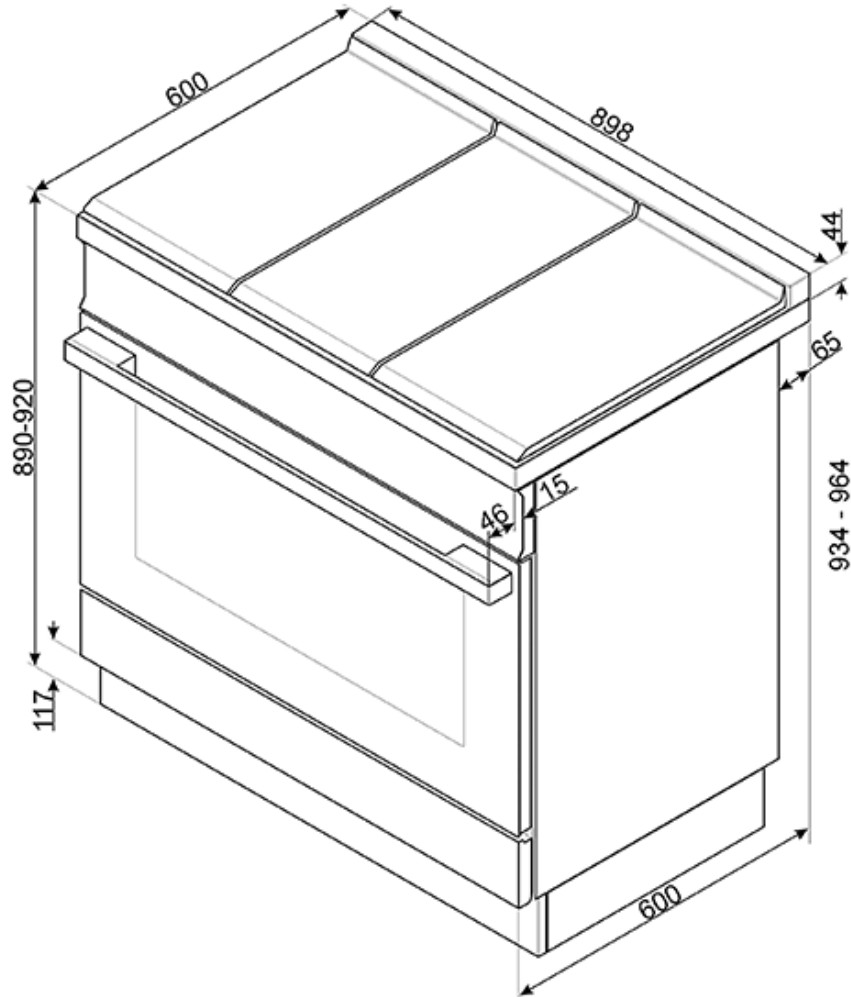

SMEG S.p.A.
Via Leonardo da Vinci, 4
42016 Guastalla (RE)
Tel. 0522 821 1