

FAB5RRD5



Product Family	Refrigerator
Installation	Free Standing
Category	One Door
Reference width	Until 60
Reference height	Until 100
Cooling type	Static
Defrost	Automatic
Hinge type	Standard
Hinge position	Right
EAN code	8017709299613



Aesthetics

Aesthetics	50's Style	Logo colour	Chrome
Colour	Red	Side material	Steel
Finishing	Gloss	Side colour	Red
Design	Rounded	Logo	Applied
Material	Heat-moulded	Door shelves profile colour	Chrome
Handle	External	Drawers profile colour	Chrome
Handle type	Fixed	Colour of glass shelf profile	Chrome
Handle colour	Chrome		

Refrigerator compartment features



No. of adjustable shelves	2	Internal light in fridge	Yes
Type of adjustable shelves	Glass	Type of internal light (fridge)	LED

Refrigerator Inner Door

Number of adjustable door shelves	1	No. of bottle shelves	1
Adjustable door shelves with wire support	Yes	Bottle shelves with wire support	Yes

Other technical features

Type of temperature control	Electronic
Refrigerant gas type	R600a
Type of compressor	Standard
Refrigerant Quantity (gr)	19 g
Foam agent	Cyclopentane

Performance / Energy Label

			
Annual energy consumption	61 kWh/year	Sum of the volumes of the chill compartment(s) and the unfrozen compartment(s)	34 l
Energy efficiency class	D	Noise level	40 dB(A) re 1 pW
Airborne acoustical noise emission class	C	Climatic class	SN, N, ST, T
Total volume	34 l	EI	79 %

Electrical Connection

Plug	(F;E) Schuko	Voltage (V)	220-240 V
Nominal power	60 W	Frequency (Hz)	50/60 Hz
Current	0,3 A	Power supply cable length	100 cm

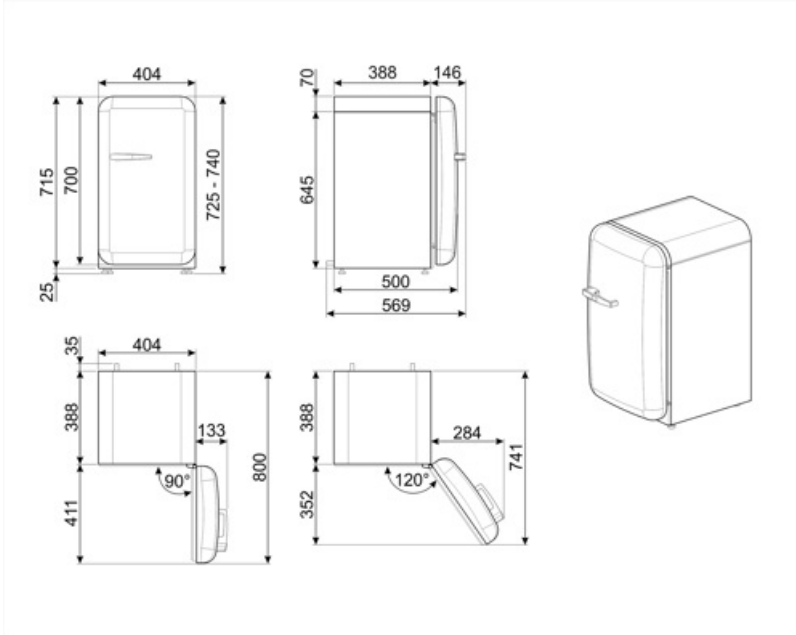

Compatible Accessories

KITCABLE90UK

Cable with IEC connector and UK plug

Alternative products



FAB5RPB5

Hinge position: Right
Pastel Blue



FAB5RCR5

Hinge position: Right
Cream



FAB5RWH5

Hinge position: Right
White



FAB5RDUJ5

Hinge position: Right
Decorated / Special



FAB5RSV5

Hinge position: Right
Silver



FAB5RPK5

Hinge position: Right
Pink



FAB5RBL5

Hinge position: Right
Black



FAB5RPG5

Hinge position: Right
Pastel Green



FAB5ROR5

Hinge position: Right
Orange

Symbols glossary



The automatic defrost system works by automatically defrosting at regular intervals eliminating the need to defrost altogether.



Energy efficiency class D



A+++: Appliances with this symbol can reduce energy consumption by a further 30% from the standard A energy rating.



LED interior lighting: is a more energy efficient and long lasting way of illuminating the interior of the appliance.

Benefit

Refrigerant gas R600a

Environmentally friendly R600a refrigerant gas contributes to rapid cooling with lower energy consumption

Climate class

Climatic class SN-T makes the appliance suitable for working at room temperature between 10 °C and 43 °C (50 °F ~ 109 °F)

External handle

The external handle ensures practicality and ease of use of the refrigerator

Refrigerator Internal lighting

Interior lighting for perfect visibility of shelves in the refrigerator compartment