

FQ60XDE



| | |
|------------------|--|
| Product Family | Refrigerator |
| Installation | Free Standing |
| Category | 4 Doors |
| Reference width | Higher than 80 |
| Reference height | 160 - 200 |
| No-Frost system | Total |
| Cooling type | Total No Frost - Double Cooling system |
| Defrost | Automatic |
| Hinge type | Standard |
| EAN code | 8017709337698 |



Aesthetics



| | | | |
|-----------------|-----------------|-------------------------------|--------------------|
| Aesthetics | Universal | Side material | Steel |
| Colour | Inox Look | Side colour | Silver |
| Finishing | Fingerproof | Logo | Applied |
| Design | Flat | Door shelves profile colour | Silver |
| Material | Steel Effect | Drawers profile colour | Silver |
| Door steel type | Finger proof | Colour of glass shelf profile | Silver |
| Handle | External | Display | LED |
| Handle type | Fixed | Display position | External (on door) |
| Handle colour | Stainless steel | Colori disponibili | White, Black |
| Logo colour | Chrome | | |

Refrigerator compartment features



| | | | |
|---|------------------|---|-------|
| No. of adjustable shelves | 2 | Type of crisper/vegetable drawers cover | Glass |
| Number of fruit and vegetables drawers | 2 | No. of lights | 2 |
| Type of adjustable shelves | Glass | Life Plus zone-0°C | Yes |
| Type of crisper/vegetable drawers cover | On sliding rails | Internal light in fridge | Yes |
| Crisper Cover | Yes | Type of internal light (fridge) | LED |

Refrigerator Inner Door

| | | | |
|--|---|-----------------------|---|
| No. of door shelves with transparent cover | 2 | No. of bottle shelves | 2 |
| Number of adjustable door shelves | 2 | | |

Other Refrigerator features



| | | | |
|------------------------|----------|----------------------------|-----|
| Accessories | Egg tray | Fan | Yes |
| Natural Plus Blu Light | Yes | Antibacterial odour filter | Yes |
| MultiFlow | Yes | | |

Freezer compartment features

| | | | |
|-------------------|---|-----------------|-------|
| Number of drawers | 4 | Type of shelves | Glass |
| No. of shelves | 2 | | |

Other Freezer features



| | | | |
|-------------|-------------|---------------------------|-----|
| Accessories | 2 ice boxes | Fast freezing compartment | Yes |
|-------------|-------------|---------------------------|-----|

Other technical features

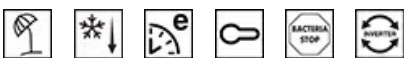

| | |
|-----------------------------|---|
| Functions display | Holiday, Fast freezing, Fast cooling, ECO, Control lock |
| Fast freezing button | Yes |
| Temperature alarm lamp | Yes |
| Door open alarm | Yes |
| Temperature Alarm | Yes |
| Antibacterial Gasket | Yes |
| Type of temperature control | Electronic |
| No. of compressors | 1 |
| Refrigerant gas type | R600a |
| Type of compressor | Variable Speed Compressor |
| Foam agent | Cyclopentane |

Performance / Energy Label



| | |
|-------------|------------------|
| Noise level | 37 dB(A) re 1 pW |
|-------------|------------------|







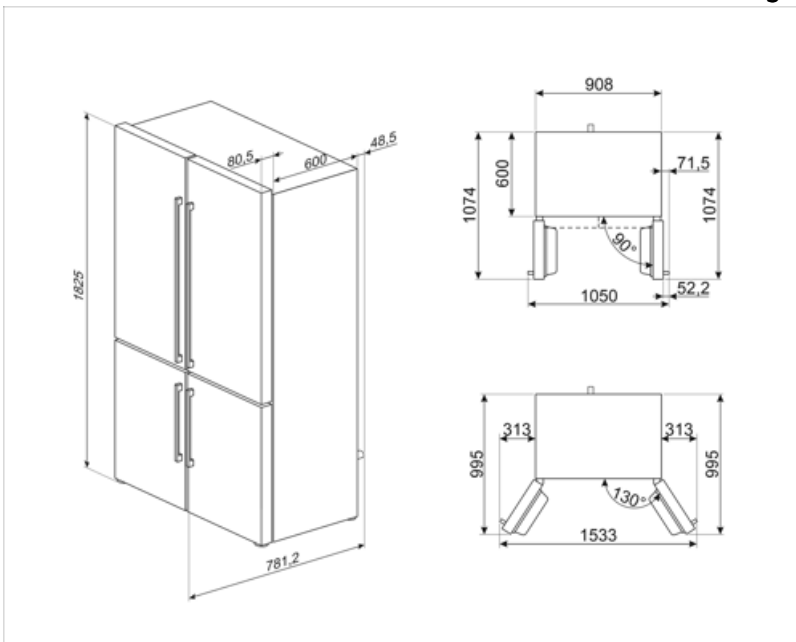







| | | | |
|---|--------------|-----------------------------------|--------------|
| Annual energy consumption | 338 kWh/year | Thaw time | 10 h |
| Energy efficiency class | E | 4 star - Freezing capacity | 4,6 Kg/24h |
| Airborne acoustical noise emission class | C | 4 star - Freezing capacity | 4,6 Kg/24h |
| Total volume | 541 l | Climatic class | SN, N, ST, T |
| Sum of the volumes of the frozen compartment(s) | 165 l | EI | 100 % |
| Sum of the volumes of the chill compartment(s) and the unfrozen compartment(s) | 376 l | | |

Electrical Connection

| | | | |
|----------------------|--------------|----------------------------------|-----------|
| Plug | (F;E) Schuko | Voltage (V) | 220-240 V |
| Nominal power | 200 W | Frequency (Hz) | 50 Hz |
| Current | 0,8 A | Power supply cable length | 240 cm |



Symbols glossary

| | | | |
|--|--|---|---|
|  | <p>The automatic defrost system works by automatically defrosting at regular intervals eliminating the need to defrost altogether.</p> |  | <p>Antibacterial treatment: antibacterial treatment to ensure better hygiene</p> |
|  | <p>Child lock: some models are fitted with a device to lock the programme/cycle so it cannot be accidentally changed.</p> |  | <p>Energy efficiency class E</p> |
|  | <p>LED display: to show programmes, functions and options selected and the time to the end of the cycle.</p> |  | <p>Economical mode: Analyzes fridge functioning during the activation and optimizes the operating cycle in order to reduce power consumption.</p> |
|  | <p>Ventilated: Forced distribution of cold air in the refrigerator compartment, which allows even temperature distribution within the fridge.</p> |  | <p>Fast freezing: The fast freezing function brings the temperature of the compartment down when activated a few hours prior to usage.</p> |
|  | <p>Fingerprint proof stainless steel: Fingerprint proof stainless steel keeps stainless steel looking as good as new.</p> |  | <p>Power saving mode: The power saving mode allows you to disable the refrigerator and keep the freezer working.</p> |
|  | <p>LED interior lighting: is a more energy efficient and long lasting way of illuminating the interior of the appliance.</p> |  | <p>Life Plus 0°C: The temperature in the Lifeplus compartments is kept at 0°C, which preserves fresh meat and fish longer.</p> |
|  | <p>Inverter technology: The evolution of Smeg's driers towards more intelligent and environmentally sustainable models has led to the choice of using Inverter technology with heat pumps, which reduces significantly energy consumption.</p> |  | <p>Air plus: keeps food fresher for longer.</p> |
|  | <p>Natural Plus Blu Light: This unique Natural Plus Blu Light system works with nature to increase the storage time of fruit and vegetables.</p> | | |

Benefit

No-Frost system

The No Frost system prevents the formation of ice and contributes to better preservation of food in the refrigerator

Natural Plus Blue Light

The Natural plus Blue light system extends the shelf life of fruit and vegetables while preserving their organoleptic properties

Plastic multiflow system

The Multiflow system ensures even distribution of cold air inside the refrigerator

Fan

The fan contributes to an even distribution of air inside the refrigerator

Refrigerant gas R600a

Environmentally friendly R600a refrigerant gas contributes to rapid cooling with lower energy consumption

External handle

The external handle ensures practicality and ease of use of the refrigerator

Life Plus 0°

Temperature-controlled Life Plus compartment for optimal storage of specific food categories

Refrigerator Internal lighting

Interior lighting for perfect visibility of shelves in the refrigerator compartment

Fruit and vegetable drawer

The fruit and vegetable drawer ensures the best storage conditions for fresh food, avoiding any contamination

Inverter compressor

Inverter compressor reduces noise and vibration levels for a quiet and comfortable kitchen environment

Inverter compressor technology offers significant advantages for refrigeration systems, improving both performance and efficiency. Better temperature control ensures a more stable and constant indoor environment, preserving the freshness of food. This technology also results in reduced energy consumption, as the compressor adjusts its speed according to cooling needs.

External display

External display for simple and intuitive control with quick access to information