

KFAB75BL

Product family	Hood
Hood Type	Chimney Cooker Hoods
Design	Angled
Extraction	Re-circulation only
Electronic control	Yes
Material	Painted material
Type of steel	Brushed
EAN code	8017709224868
Aesthetics	50's Style
Colour	Black
Finishing	Gloss
Logo	Applied



Controls

Control setting	Electronic buttons	Led colour	White
-----------------	--------------------	------------	-------

Program / Functions

No. of speeds	3
Intensive speed	
Time-setting options	

Technical Features



No. of lights	2	Anti-grease filters	Stainless steel
Light type	LED	Charcoal filters included	Yes
Light power	1 W	Filter replacement indicator	Yes
Light colour temperature scale (°K)	4000 °K	Vent outlet	150 mm
Free outlet maximum capacity	820 m³/h	Minimum distance from GAS hob	650 mm
Motor power	280 W	Minimum distance from ELECTRIC hob	650 mm
No. of filters	3	Non return valve	Yes

	Extraction rate IEC 61591 [m³/h]	Noise level IEC 60704-2-13 [dBA]
Speed 1	333	50

Speed 2	477	59
Speed 3	649	67
Intensive speed	797	72

Accessories Included

Remote control	Yes	Sliding door	Yes
----------------	-----	--------------	-----

Performance / Energy Label



Annual Efficiency Consumption (AEChood)	36 KWh/year	Airbourne acoustical A-weighted sound Power Emission at minimum speed (SPEmin)	50 dBA
Energy efficiency class (EEC)	A+	Airborne acoustical A-weighted sound Power Emission at maximum speed (SPEmax)	67 dBA
Fluid Dynamic Efficiency (FDE)	36,6	Airbourne acoustical A-weighted sound power emission at boost speed (SPEboost)	72 dBA
Fluid Dynamic Efficiency class (FDEC)	A	Time increase factor (F)	0,7
Lighting Efficiency (LE)	68,2 lux/W	Energy Efficiency Index per first cavity	39,7
Lighting Efficiency Class (LEC)	A	Measured air flow rate at best efficiency point (Qbep)	421 m ³ /h
Grease Filtering Efficiency (GFE)	61,1 %	Measured air pressure at best efficiency point (Qbep)	422 Pa
Grease Filtering Efficiency Class (GFEC)	E	Measured electric power input at best efficiency point (Wbep)	135 W
Air flow at mininum speed (Qmin)	333 m ³ /h	Normal Power of the light system (WI)	2 W
Maximum extraction rate	649 m ³ /h	Average illumination of the light on the cooking surface (Emiddle)	150 lux
Intensive extraction rate	797 m ³ /h	Sound power level at highest setting (Lwa)	67 dBA

Electrical Connection

Battery type	Alkaline-Manganese Dioxide (Zn/MnO ₂)	Voltage	220-240 V
Nominal power	282 W	Frequency (Hz)	50-60 Hz
Current	1 A	Power supply cable length	1500 mm

Also available

Alternative colours available

White, Cream, Blue, Red

Available colours

KFAB75WH-KFAB75CR-
KFAB75UJ-KFAB75RD

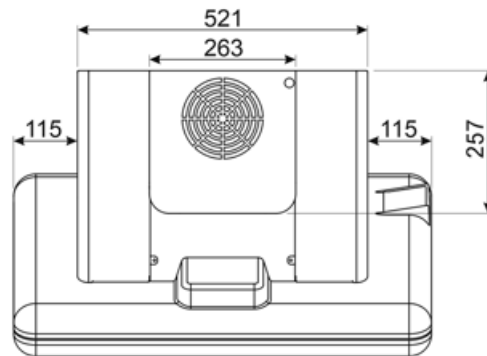
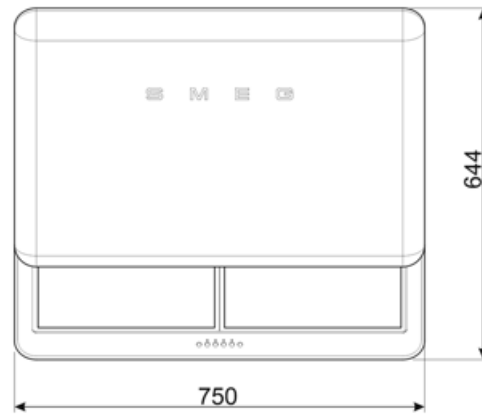
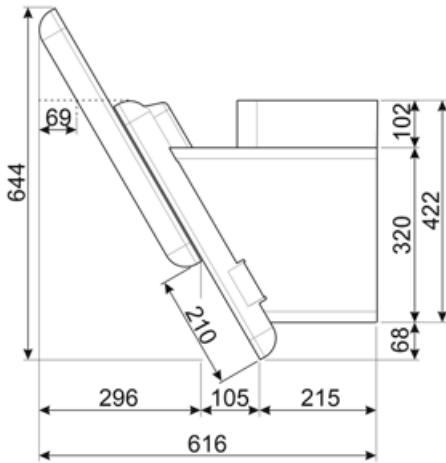

Compatible Accessories

FLTSI







Charcoal filters Kit 2 pieces



KITCMNFABBL

Coppia di Camini (2 pezzi) dimensioni
550 min 1035 max (263 * 257 mm)
KFAB75BL NERA

Symbols glossary

- | | | | |
|--|---|---|--|
|  | Filters: Model has filters to help remove grease from the steam emanating from the pans during cooking. |  | Switch off automatically: A special setting, to run after the end of cooking for a pre-set time and then switch off automatically. |
|  | Charcoal filters: Extracting through charcoal filters or directly to the exterior lessens strong cooking odours considerably. |  | A+: Energy efficiency class A+ helps to save up to 10% energy compared to class A. Maximum performance with minimum consumption is guaranteed. |
|  | Warning light(s): to advise when filters need changing. |  | Lights: All cooker hoods feature lights to illuminate the cooking area or add to the ambience of the kitchen. |
|  | Intensive/turbo setting: when extra fast extraction is required. | | |