

**Series 4, Built-in fridge-freezer with freezer at bottom, 177.2 x 54.1 cm, flat hinge  
KIN86VFE0G**



**The spacious built-in fridge-freezer combination with VitaFresh XXL and NoFrost keeps food fresh for longer and prevent ice formation.**

- **EcoAirflow:** optimal air circulation and a constant temperature level in the cooling area.
- LED lights bring a completely new lighting concept to fridges
- **High-stability door trays:** extra high and flexible for more space and stability.
- **NoFrost:** never defrost again, thanks to perfect protection from ice formation - that saves time and effort.
- FreshSense sensors constantly monitor and control the ambient, fridge and freezer temperature

**Technical Data**

Energy Efficiency Class: E  
 Average annual energy consumption in kilowatt hour per year (kWh/a): 234 kWh/annum  
 Sum of volume of frozen compartments: 76 l  
 Sum of volume of chill compartments: 184 l  
 Airborne acoustical noise emissions : 35 dB(A) re 1 pW  
 Airborne acoustical noise emission class: B  
 Construction type: Built-in  
 Door panel options: Possible but accessory  
 Height: 1772 mm  
 Width of the appliance: 541 mm  
 Depth of the product: 548 mm  
 Min. required niche size for installation (HxWxD): 1775.0 x 560 x 550 mm  
 Net weight: 54.4 kg  
 Fuse protection: 10 A  
 Door hinge: Right reversible  
 Voltage: 220-240 V  
 Frequency: 50 Hz  
 Length of electrical supply cord: 230 cm  
 Storage Period in Event of Power Failure (h): 10 h  
 Number of compressors: 1  
 Number of independent cooling systems: 1  
 Interior ventilator: No  
 Reversible Door Hinge: Yes  
 Number of Adjustable Shelves in fridge compartment (Stck): 3  
 Shelves for Bottles: No  
 Frost free system: Freezer  
 Installation type: Full-integrated  
 Type of hinge: Flush-folding

**Included accessories**

3 x egg tray  
 1 x ice cube tray



## Series 4, Built-in fridge-freezer with freezer at bottom, 177.2 x 54.1 cm, flat hinge KIN86VFE0G

**The spacious built-in fridge-freezer combination with VitaFresh XXL and NoFrost keeps food fresh for longer and prevent ice formation.**

### Key features - Fridge section

- Right hinged door, door reversible
- 220 - 240 V

### Key features - Freezer section

- 3 x egg tray, 1 x ice cube tray

### Country Specific Options

- Based on the results of the standard 24-hour test. Actual consumption depends on usage/position of the appliance.

### Design features

- easy Installation

### Performance and Consumption

- EU19\_EEK\_D: E
- Total Volume : 260 l
- Net Fridge Volume : 184 l
- Net Freezer Volume : 76 l
- Freezing capacity 24h : 4 kg
- Annual Energy Consumption: 234 kWh/a
- Climate Class: SN-ST
- Noise Level : 35 dB , EU19\_Noise emission class\_D: B
- Temperature rise time : EU19\_Temperature rise time\_D: 10 H

### Functions

- Bright interior LED fridge light

### Design features

- LED electronic control
- Super Cooling: No
- SuperFreezing function with automatic deactivation
- optical, acoustic for Fridge and Freeze

### Design features

- 4 safety glass shelves in fridge compartment of which 3 are height adjustable
- 3 door trays, including 1x dairy compartment
- 1 removable door storage compartments.
- 3 door bins

### Freshness System

- 1 VitaFresh drawer with humidity control - Fruits and vegetables retain vitamins and stay fresh for longer

### Food freshness system

- NoFrost freezer, never have to defrost ever again
- 3 freezer drawers

### Dimension and installation

- Dimensions: 177.2 cm H x 54.1 cm W x 54.8 cm D
- Niche Dimensions: 177.5 cm H x 56 cm W x 55 cm D

### Additional features

- Net 4\* compartment volume : 76 l

**Series 4, Built-in fridge-freezer with freezer at bottom, 177.2 x 54.1 cm, flat hinge KIN86VFE0G**

measurements in mm

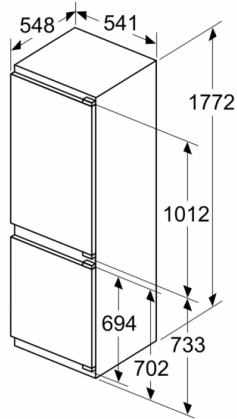

measurements in mm

Recommended gap dimensions for flat hinges

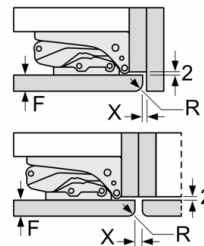

F	R	X
16-19	0-3	2.5
20	0-1	3
	2-3	2.5
21	0-1	3
	2-3	2.5
22	0	4
	1	3.5
	2-3	3

The gap dimensions recommended in the table must be adhered to in order to ensure that appliance doors do not collide with anything when they are opened, and to avoid causing damage to kitchen units.

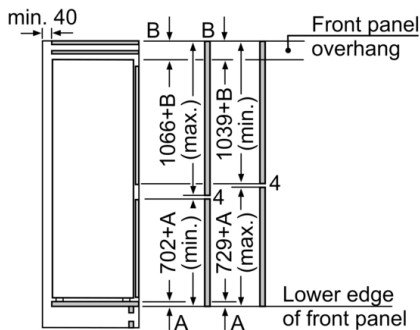

The specified unit door dimensions are valid for a door gap of 4 mm.

measurements in mm

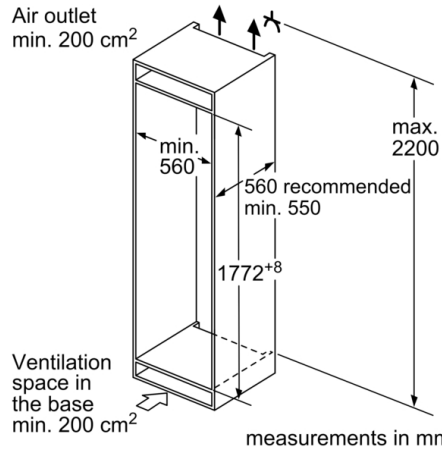

measurements in mm

