



**Advanced cooking functions. For great results in half the time**  
 The 9000 ProAssist CombiQuick® Oven merges hot air circulation with advanced microwave technology for even cooking results in half the time. And the automatic functions adjust settings for perfect dishes every time.

**Product Benefits & Features**



**Microwave and Oven. Dual functions for delicious dishes**  
 Microwave and Oven merges hot air circulation with advanced microwave technology for grilling, roasting and baking up to 50% faster than a conventional oven.



**Enhance your cooking experience and results with CookSmart Touch+**  
 CookSmart Touch+ is an interface that enhances your cooking experience, guiding you to perfect results while helping save energy. Your favourite dishes and methods can be saved on the app and sent to the oven at the touch of a button.



**Functions and Dishes. Automatic settings and step-by-step guidance**  
 Assisted cooking Functions provide the best settings and automatic options such as Roast, Reheat and Dough Prove for outstanding results. And the Assisted Dishes function offers step-by-step guidance for meat, baking, cooking plant-based dishes, fish or vegetables.



**Ensure precise cooking with the new Food Sensor**  
 The new Food Sensor notifies you when your desired temperature is reached and allows you to precisely monitor the cooking process to achieve perfect results every time.



**Cooked Evenly everywhere**  
 The clever Hot Air convection system ensures hot air circulates evenly throughout the oven cavity, for a cooking process that is faster, and more energy efficient.

- Connectivity: Control your oven via your smartphone or tablet.
- Our award winning 8-inch display screen with intuitive touch control for easy use.
- Temperature probe
- SoftMotion™ for a smooth, silent action when closing the door.
- Cooling fan
- Residual heat cooking uses the leftover heat in the oven to finish the cooking process, helping to reduce energy consumption.
- Microwave function
- Fan controlled defrosting: Great for delicate items like cream cakes, by using room-temperature air to defrost food in half the time.
- LED digital display
- Isofront® plus triple glazed doors with a heat reflective coating.
- Child lock: Oven controls can be locked to prevent misuse, providing safety and peace of mind.
- Turbo grilling
- Inverter microwave technology cooks food evenly, preventing hot spots by spreading heat consistently.

#### Product Specification

Main Colour	Black
Built-in Dimensions (mm) (HxWxD)	450x560x550
Functions (Main Oven)	Dough proving, Grill, Grill + Microwave, Hot air, Hot air & Bottom, Hot air & Top, Keep warm, Melt, Microwave, Plate warming, Preserving, Reheating, Roast, Slow Cooking, Stew, Top, Top & Bottom, True fan cooking + Microwave, Turbo grilling + Microwave, Bottom, Bread baking, Conventional cooking + Microwave, Defrost, Dehydrating
Connectivity	Yes
Total Electricity Loading (W)	3000
Steam Category	No
Timer Type	CookSmart touch+ (8 inch display)
Main Oven - Internal Capacity (L)	44
Cleaning	Clean enamel
Dimensions (mm) (HxWxD)	455x595x567
Oven control type	Touch
Max Power Grill - Top Oven (W)	1900
Max power oven, W	3000
Temperature Range	30°C - 230°C
Interior Light	1, Top halogen
Lamp power (W)	25

Oven Energy Source	Electrical
Product Type	Built-in Electric Oven
Gross Weight (Kg)	36
Net Weight (Kg)	34.3
Main Oven - Trays Included	1 Cake tray grey enamel, 1 Dripping pan grey enamel, 1 Trivet chromed
Main Oven - Shelves Included	1 Wire shelf chromed
Main Oven - Shelf Support	Side grids Easy entry
Cord Length (m)	1.5
Plug or Hardwired	Hardwired connection only
N° of cavities	1
PNC	944 005 196
Bar Code	7333394104225
Required Fuse (A)	16

PSGBOV230DE00001

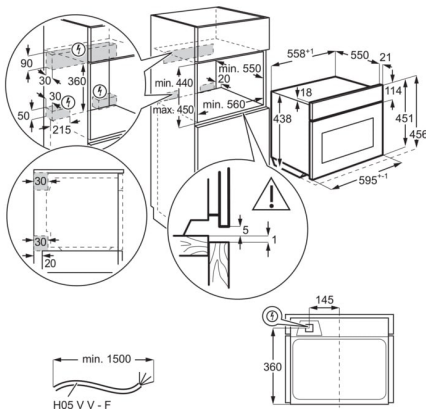

PSGBOV230DE00002

