

# Freestanding Range Cooker, Dual Fuel, 90cm, 5 Burners

Series 7 | Contemporary

Stainless Steel



A striking addition to your kitchen, with five powerful gas burners and the cooking flexibility of two convection ovens.

- Five burner gas cooktop with wok burner
- Two independent convection ovens, one 70L total capacity and one 40L total capacity
- Seven oven functions in each oven

## DIMENSIONS

Height	870 - 925 mm
Width	900 mm
Depth	600 mm

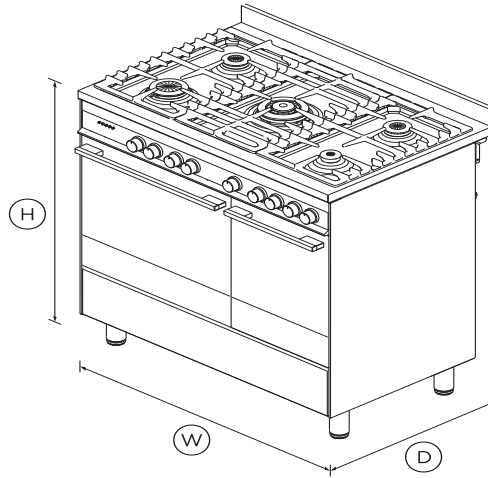

## FEATURES & BENEFITS

### Cooking flexibility

This freestanding dual fuel range cooker has seven functions with pre-set temperatures, including Bake, Grill and Fan Forced, allowing you to use a variety of cooking styles.

### Sized to suit

Designed for multi-shelf cooking, this freestanding dual fuel cooker provides 70L of total capacity in one cavity and 40L of total capacity in the other, giving you enough room for a large family roast and all the trimmings.

## SPECIFICATIONS

### Accessories

Fat filter	1
Flat wire shelf	1
Grill rack	2

### Capacity

Shelf positions	4 per cavity
Total	70L + 40L
Total capacity	70L + 40L
Usable capacity	65L + 35L

### Cleaning

- Acid resistant graphite enamel
- Removable oven door
- Removable shelf runners

### Consumption

Energy rating	B, B
---------------	------

### Controls

- Automatic cooking/minute
- Electronic clock
- Satin chrome control dials

### Oven features

- Electronic ignition
- Storage drawer

**Oven functions**

Bake	•
Defrost	•
Fan bake	•
Fan forced	•
Fan grill	•
Grill	<sup>2000W</sup><sub>1450W</sub>
Number of functions	7 + light (both ovens)
Warm	•

**Oven performance**

Grill power	2000W/1450W
-------------	-------------

**Power requirements**

Amperage	19.6A
----------	-------

**Product dimensions**

Depth	600 mm
Height	870 - 925 mm
Width	900 mm

**Hob Features**

LPG/Natural gas compatible	•
----------------------------	---

**Hob Performance**

Auxiliary burner	1kW
Cast iron trivets	•
Number of burner elements	5 including 2 semi-rapid
Semi-rapid burner	1.75kW

**Safety**

Advanced cooling system	•
Anti-tilt bracket	•
COOLTouch door	•
Flame failure	•
Flame failure system	•
Non-tip shelves	•

**Warranty**

Parts and labour	5 years
------------------	---------

SKU	81563
-----	-------

The product dimensions and specifications in this page apply to the specific product and model. Under our policy of continuous improvement, these dimensions and specifications may change at any time. You should therefore check with Fisher & Paykel's Customer Care Centre to ensure this page correctly describes the model currently available. © Fisher & Paykel Appliances Ltd 2019.

**Other product downloads available at fisherpaykel.com**

User Guide



Service &amp; Warranty Booklet

**A PEACE OF MIND SALE****24 Hours 7 Days a Week Customer Support****T 1300 650 590 W** www.fisherpaykel.com