

FISHER & PAYKEL

FREESTANDING COOKER

OR90L7 double oven
models

INSTALLATION GUIDE / USER GUIDE

GB IE

Safety and warnings	2
Installation instructions	12
Introducing your cooker	22
Using your gas cooktop	23
Cooktop troubleshooting	27
Using your main multifunction oven for the first time	28
Clock and timer	29
Using your main oven	30
Cooking functions	31
Automatic cooking	33
Using your compact multifunction oven for the first time	34
Using your compact oven	35
Cooking functions	35
Using the dish-warming shelf	38
Care and cleaning	39
Warranty and service	49

Important!

SAVE THESE INSTRUCTIONS

The models shown in this User Guide may not be available in all markets and are subject to change at any time. For current details about model and specification availability in your country, please visit our local website listed on the back cover or contact your local Fisher & Paykel dealer.

Installation

⚠ WARNING!



Electrical Shock Hazard

Always disconnect the cooker from the mains electricity supply before carrying out any maintenance operations or repairs.

Failure to do so may result in death or electrical shock.

⚠ WARNING!



Cut Hazard

Take care - panel edges are sharp.

Failure to use caution could result in injury or cuts.

Important safety precautions

General

- ***To avoid hazard, follow these instructions carefully before installing or using this product.***
- ***Please make this information available to the person installing the product as it could reduce your installation costs.***
- ***Installation must comply with your local building and electricity regulations.***
- ***Failure to install the cooker correctly could invalidate any warranty or liability claims.***

- *Some appliances have a protective film. Remove this film before using the cooker.*
- *After unpacking the appliance, check to ensure it is not damaged and the door closes correctly. If in doubt, do not use it and consult your Fisher & Paykel dealer or a professionally qualified technician.*

Electrical

- *This cooker is to be installed and connected to the electricity supply only by an authorised person.*
- *If the installation requires alterations to the domestic electrical system call a qualified electrician. He should also check that the electrical system is suitable for the electricity drawn by the cooker.*
- *The appliance must be connected to the mains, checking that the voltage corresponds to the value given in the rating plate and that the electrical cable sections can withstand the load specified on the plate.*
- *A suitable disconnection switch must be incorporated in the permanent wiring, mounted and positioned to comply with the local wiring rules and regulations. The switch must be of an approved type installed in the fixed wiring and provide a 3 mm air gap contact separation in all poles in accordance with the local wiring rules.*

Electrical

- *The switch must always be accessible.*
- *The power supply cable must not touch any hot parts and must be positioned so that it does not exceed 75 °C at any point and cannot become entrapped in the oven door.*
- *To connect the cooker to the mains, do not use adapters, reducers or branching devices as they can cause overheating and burning.*
- *This cooker must be connected to a suitable double pole control unit adjacent to the cooker. No diversity can be applied to this control unit.*
- *The cooker must be earthed.*

Gas

- *This cooker is supplied for use with natural gas only, and cannot be used on any other gas without modification. See 'Gas installation' for modification to other gas types.*
- *This cooker can only be installed in a room with adequate ventilation. See the 'Ventilation requirements' in the installation instructions .*

General

- *Do not leave packing elements (plastic bags, polystyrene foam, nails, packing straps etc) around within easy access of children, as these may cause serious injuries.*
- *Read the instructions carefully before installing and using the appliance.*
- *The manufacturer declines all liability for injury to persons or damage to property caused by the incorrect use or improper use of the appliance.*
- *If you should decide to dispose of this cooker, we recommended that it be made inoperative in an appropriate manner in accordance to health and environmental protection regulations. In particular, ensure that all potentially hazardous parts are made harmless, especially in regard to children who could play with unused appliances.*
- *Various components of the appliance are recyclable. Dispose of them in accordance with the regulations in force in your country. If the appliance is to be scrapped, remove the power cord.*

6 Safety and warnings

Operation

Your freestanding cooker has been carefully designed to operate safely during normal cooking procedures. Please keep the following guidelines in mind when you are using it:

⚠ WARNING!

Explosion Hazard



Do not store flammable materials such as gasoline near the cooktop.

Do not store flammable material in the ovens or in the storage compartment. Do not spray aerosols near the cooktop during use.

Failure to do so may result in death or serious injury.

⚠ WARNING!



Electrical Shock Hazard

Switch the cooker off at the wall before replacing fuses or the oven lamp.

Failure to do so may result in death or electrical shock.

⚠ WARNING!**Hot Surface Hazard**

Accessible parts will become hot when this cooker is in use.

To avoid burns and scalds keep children away.

Do not touch hot surfaces inside the ovens.

Use oven mitts or other protection when handling hot surfaces such as oven shelves or dishes.

Take care when opening the oven doors. Let hot air or steam escape before removing or replacing food.

Do not touch the cooktop components, burners, trivets/pan supports or the base when hot.

Before cleaning, turn the cooker off and make sure it is cool.

Failure to do so could result in burns and scalds.



Important safety precautions

- *Never leave the appliance unattended when in use. Boilover causes smoking and greasy spillovers that may ignite. NEVER try to extinguish a fire with water. Switch the appliance off at the wall and then cover the flame with a lid or fire blanket.*
- *Isolating switch: make sure this cooker is connected to a circuit which incorporates an isolating switch providing full disconnection from the power supply.*
- *Household appliances are not intended to be played with by children. Children of less than 8 years old must be kept away from the appliance unless continuously supervised. This appliance can be used by children aged from 8 years and above, and persons with reduced physical, sensory or mental capabilities or lack of experience and knowledge, if they have been given supervision or instruction concerning the use of the appliance in a safe way and they understand the hazards involved.*
- *Cleaning and user maintenance shall not be done by children without supervision.*
- *Safe food handling: leave food in the oven for as short a time as possible before and after cooking. This is to avoid contamination by organisms which may cause food poisoning.*

Take particular care during warmer weather.

- *Do not place aluminium foil, dishes, trays, water or ice on the oven floor during cooking as this will irreversibly damage the enamel.*
- *Do not line the walls with aluminium foil.*
- *Do not stand on the doors, or place heavy objects on them.*
- *Do not use harsh abrasive cleaners or sharp metal scrapers to clean the oven door glass since they scratch the surface, which may result in shattering of the glass.*
- *Do not use a steam cleaner to clean any part of the cooker.*
- *Do not use an asbestos mat or decorative covers between the flame and the saucepan as this may cause serious damage to your cooktop. Do not place aluminium foil or plastic dishes on the cooktop burners.*
- *Do not let large saucepans or frying pans overlap the bench as this can deflect heat onto your benchtop and damage the surface.*
- *Do not let large saucepans, frying pans or woks push any other pans aside. This could make them unstable or deflect heat onto your benchtop and damage the surface.*
- *Saucepan handles may be hot to touch. Ensure saucepan handles do not overhang other gas burners that are on. Keep handles out of reach of children.*

- *Do not hang towels, dishcloths or other items on the cooker or oven door handle as this is a potential a fire hazard.*
- *If the electrical supply cord is damaged, it must only be replaced by an authorised person.*
- *Do not touch the cooker with wet hands or feet. Do not operate whilst in bare feet.*
- *This cooker is not to be used as a space heater.*
- *The use of a gas cooking appliance results in the production of heat and moisture in the room in which it is installed. Ensure the kitchen is well ventilated. Keep natural ventilation holes open or install a mechanical ventilation device (mechanical extractor hood). Prolonged intensive use of the appliance may call for additional ventilation, for example opening of a window, or more effective ventilation, for example increasing the level of mechanical ventilation where present.*
- *Do not operate the cooker by means of an external timer or separate remote-control system.*
- *Do not modify this appliance as it may become dangerous to use. The manufacturer declines all responsibility for any inconvenience or damage to persons or property arising from the non-observance of this condition.*

- *The manufacturer declines all liability for damage to property cause by the incorrect or improper use of the appliance.*
- *Important! This appliance is designed and manufactured solely for the cooking of domestic (household) food and it not suitable for any non domestic application and therefore should not be used in a commercial environment.*
- *The appliance guarantee will be void if the appliance is used with in a non domestic environment ie a semi-commercial, commercial or communal environment.*

12 Installation instructions

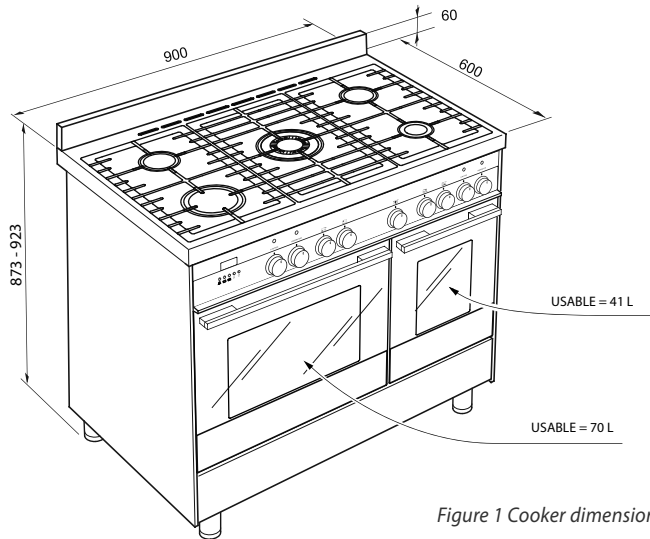

Figure 1 Cooker dimensions and capacity

The cooker must be installed by a qualified technician and in compliance with local safety standards. This cookers has class "2/1" overheating protection so that it can be installed next to a cabinet.

If the cooker is installed adjacent to furniture which is higher than the gas hob cooktop, a gap of at least 200 mm must be left between the side of the cooker and the furniture.

The furniture walls adjacent to the cooker must be made of material resistant to heat. The veneered synthetical material and the glue used must be resistant to a temperature of 90°C in order to avoid ungluing or deformations.

The cooker may be located in a kitchen, a kitchen/diner or bed-sitting room but not in a room containing a bath or shower.

Curtains must not be fitted immediately behind appliance or within 500 mm of the sides.

If the cooker is located on a pedestal it is necessary to provide safety measures to prevent falling out.

It is essential that the cooker is positioned as stated.

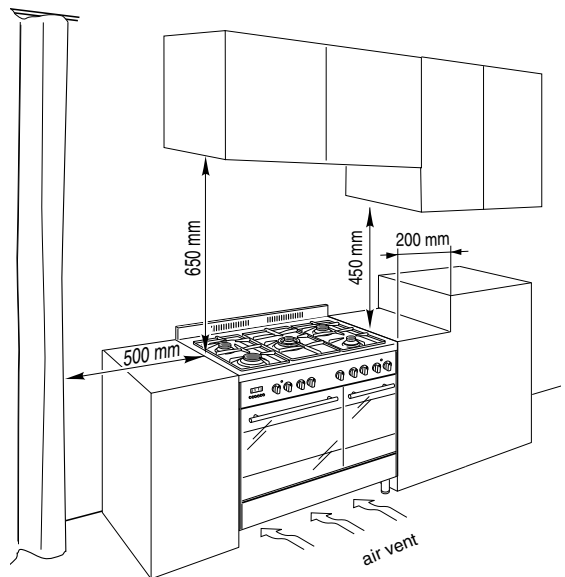

Figure 2 Correct distances from cooker

Fitting the adjustable feet

Important!

Using the supplied adjustable feet is MANDATORY. For safety reasons and to ensure adequate ventilation, the cooker chassis MUST NOT sit directly on the floor, a plinth, or other support surface.

The adjustable feet must be fitted to the base of the cooker before use.

Rest the rear of the cooker on a piece of the polystyrene packaging exposing the base for the fitting of the feet.

Fit the four legs by screwing them tight into the support base as shown.

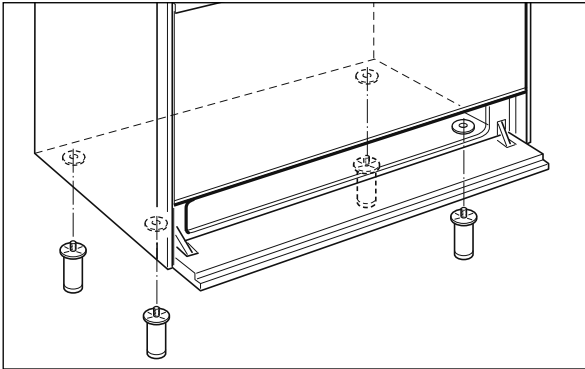

Figure 3 Location of feet

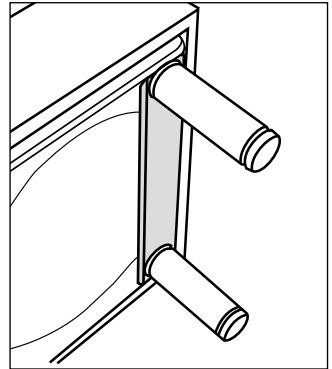

Figure 4 Top of feet screwed in tightly

Levelling the cooker

Level the cooker by screwing the bottom of the feet in or out, as shown.

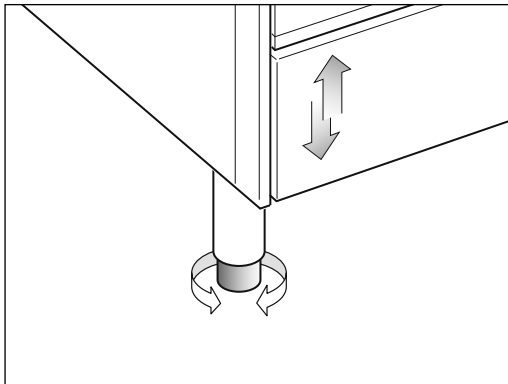

Figure 5 Levelling the cooker

Moving the cooker

Important!

Two people must always raise the cooker, as shown, to prevent damaging the adjustable feet.

Do not lift the cooker by the door handles.
DO NOT DRAG the cooker. Lift the feet clear of the floor.

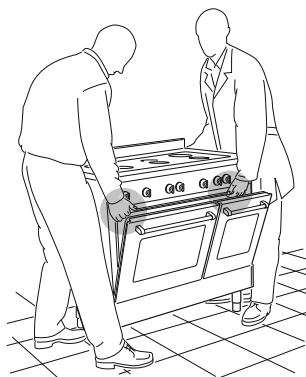

Figure 6 Correctly raising the cooker



Figure 7 Incorrectly moving the cooker

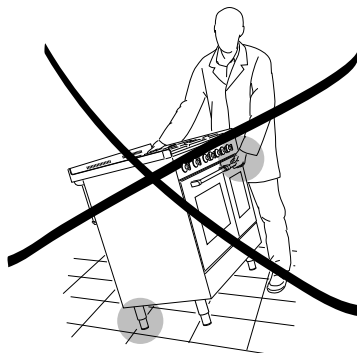

Figure 8 Incorrectly raising the cooker

Backguard

Before installing the cooker, assemble the backguard "C".

- The backguard "C" can be found packed at the rear of the cooker.
- Before assembling remove any protective film/adhesive tape.
- Remove the two spacers "A" and the screw "B" from the rear of the cooktop.
- Assemble the backguard as shown and fix it by screwing the central screw "B" and the spacers "A".

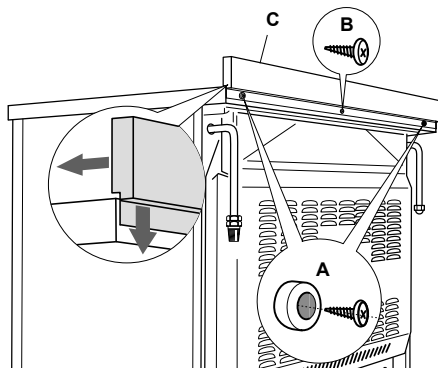

Figure 9 Assembling the backguard

Anti-Tilt Bracket

Important!

To restrain the appliance and prevent it tipping accidentally, fit a bracket to its rear to fix it securely to the wall.

To fit the anti-tilt bracket:

- 1 After you have located where the cooker is to be positioned, mark on the wall the place where the two screws of the anti-tilt bracket have to be fitted. Please follow the indications given in Fig. 10.
- 2 Drill two 8 mm diameter holes in the wall and insert the plastic plugs supplied.

Important!

Before drilling the holes, check that you will not damage any pipes or electrical wires.

- 3 Loosely attach the anti-tilt bracket with the two screws supplied.
- 4 Move the cooker to the wall and adjust the height of the anti-tilt bracket so that it can engage in the slot on the cooker's back, as shown in fig. 10.
- 5 Tighten the screws attaching the anti-tilt bracket.
- 6 Push the cooker against the wall so that the anti-tilt bracket is fully inserted in the slot on the cooker's back.

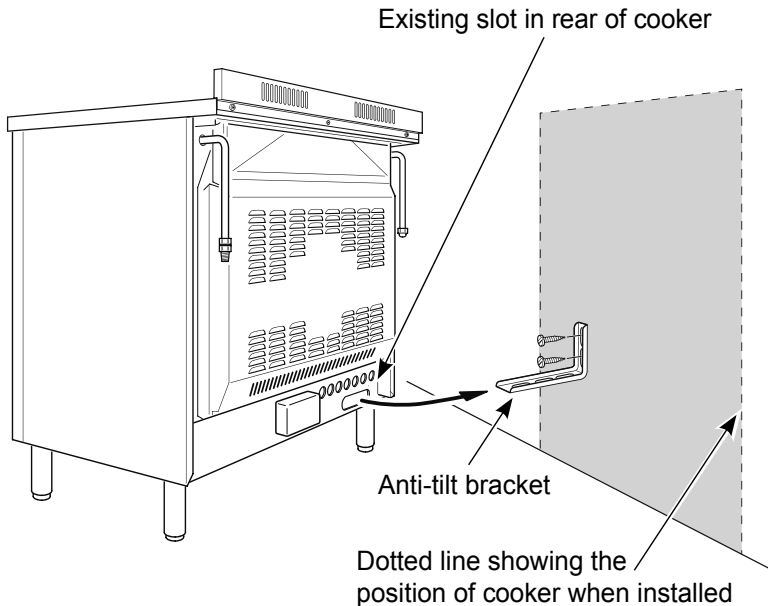

Figure 10 Fitting a stability bracket

Ventilation requirements (GB & IE only)

The appliance should be installed into a room or space with an air supply in accordance with BS 5440-2:2000.

For rooms with a volume of less than 5 m³ - permanent ventilation of 100 mm² free area will be required.

For rooms with a volume of between 5 m³ and 10 m³ a permanent ventilation of 50 cm² free area will be required unless the room has a door which opens directly to the outside air in which case no permanent ventilation is required.

For rooms with a volume greater than 10 m³ - no permanent ventilation is required.

Important!

Regardless of room size, all rooms containing the appliance must have direct access to the outside air via an openable window or equivalent.

Where there are other fuel burning appliances in the same room, BS 5440-2:2000 should be consulted to determine the correct amount of free area ventilation requirements.

Gas installation (GB & IE only)

Important!

This cooker uses NATURAL GAS only and cannot be used on any other gas without modification. This appliance is manufactured for conversion to LPG if required. If the injectors are not supplied they can be obtained from the After-Sales Service.

Installation and service regulations

Important!

This appliance must be installed and serviced only by a suitably qualified and registered person, and in accordance with the current editions of the following standards and regulations or other locally applicable regulations:

- ***Gas Safety (Installation and Use) Regulations***
- ***Building Regulations***
- ***British Standards***
- ***Regulations for Electrical Installation***

Failure to install the appliance correctly could invalidate any manufacturer's warranty and lead to prosecution under the above-quoted regulation.

Gas connection

The installation of the cooker to Natural Gas or LP Gas must be carried out by a qualified gas engineer. Installers shall take due account of the provisions of the relevant British Standards Code of Practice, the Gas Safety Regulations and the Building Standards (Scotland) (Consolidation) Regulations issued by the Scottish Development Department.

Note: It is recommended that the gas connection to the cooker is installed with a flexible connecting tube made to BS 5386.

Installation to Natural gas

Installation to Natural Gas must conform to the Code of Practice, etc. The supply pressure for Natural Gas is 20 mbar.

Installation to Liquid Petroleum gas

This appliance must only be connected to LPG after an LPG conversion kit has been fitted. The installation must conform to the relevant British Standards.

Important!

Only a suitably qualified and registered person may convert the appliance to a different gas type.

- When using Butane gas a supply pressure of 28 -30 mbar is required.
- When using Propane gas a supply pressure of 37 mbar is required.

Notes:

- Flexible hoses can be used where the sited ambient temperature of the hose does not exceed 70°C. These hoses must be manufactured in accordance with BS669 part 1 and be of the correct construction for the type of gas being used.
- Gas hoses designed for natural gas **MUST NOT** be used for supplying LPG gas (LPG gas hoses can be identified by either a red band or stripe on the rubber outer coating of the hose).
- The hose should not be crushed or trapped or be in contact with sharp or abrasive edges. It should also not be subjected to corrosion by acidic cleansing agents.

To connect the gas supply:

- 1 Fit the 1/2" BSP (female) connector (supplied with the cooker in a separate kit) to the gas inlet at the rear of the cooker interposing the gasket. Check the correct positioning of the connector as shown and always use two suitable spanners (Fig 11b).
- 2 Connect the gas supply to the right or left gas inlet at the rear of the cooker. The pipe is not to cross the cooker.
- 3 Close the unused end inlet pipe with a plug, interposing the gasket (Fig. 11a - Fig. 11b).
- 4 To avoid damage to the appliance gas rail inlet pipe tighten the fittings using two suitable spanners (Fig. 11b).
- 5 Using a suitable leak detection fluid solution (e.g. Rocol) check each gas connection one at a time by brushing the solution over the connection. The presence of bubbles will indicate a leak. If there is a leak, tighten the fitting and then recheck for leaks.

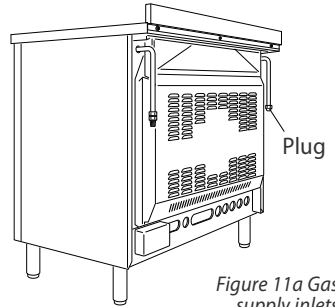

Figure 11a Gas supply inlets

IMPORTANT!

Do not use a naked flame to test for leaks.

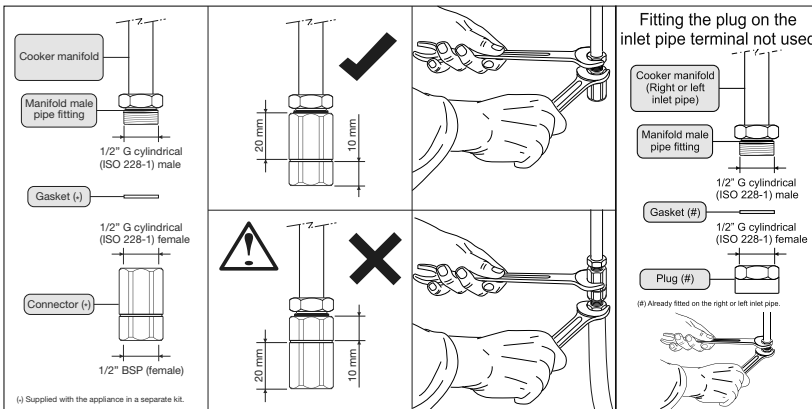

Figure 11b Connecting the gas

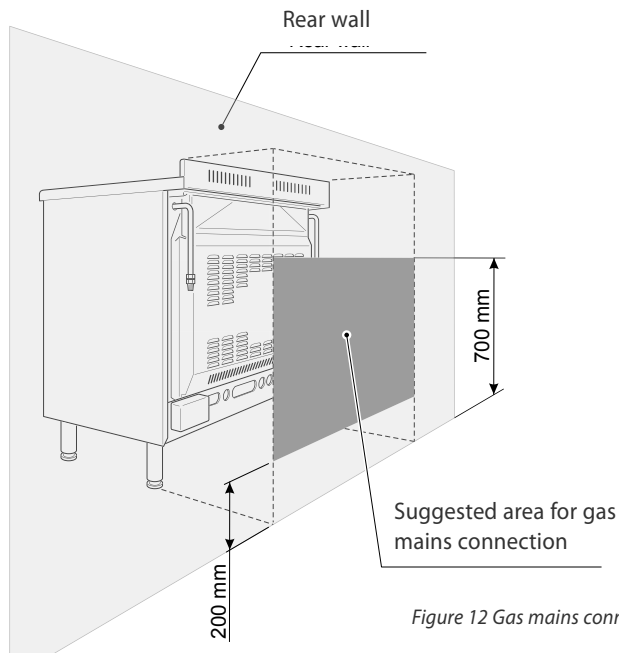

Figure 12 Gas mains connection area

Replacement of burner injectors

If the injectors are not supplied, contact the Fisher & Paykel Authorised Service Centre. Select the injectors to be replaced according to the "Table for the choice of the injectors".

To replace the injectors

Remove pan supports and burners from the cooktop. Using a wrench substitute the nozzle injectors with those most suitable for the kind of gas for which it is to be used. The burners are designed so that adjustment of primary air is not required.

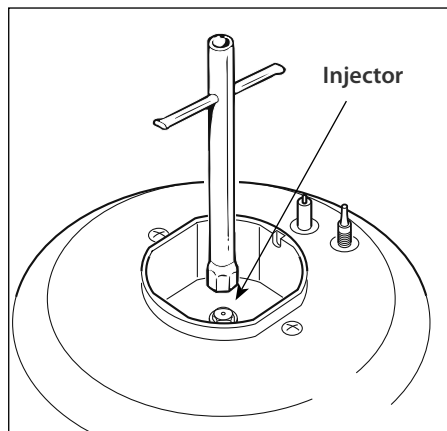

Figure 13 Auxiliary, semi-rapid and rapid burner

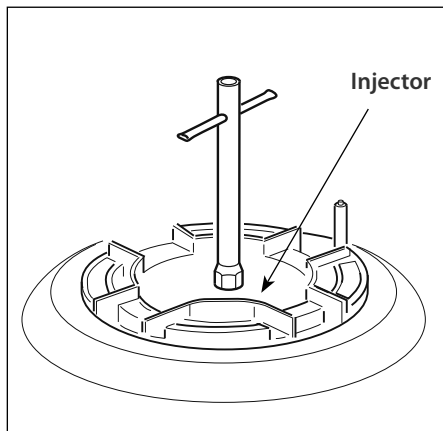

Figure 14 Triple ring wok burner

Adjusting The Minimum Burner Setting

Check whether the flame spreads to all burner ports when the burner is lit with the gas tap set to the minimum position. If some ports do not light, increase the minimum gas rate setting. Check whether the burner remains lit even when the gas tap is turned quickly from the maximum to the minimum position. If the burner does not remain lit, increase the minimum gas rate setting.

To adjust the minimum gas rate setting:

- Turn on the burner
- Turn the tap to the MINIMUM position
- Take off the knob
- With a small flat screwdriver turn the screw to the correct regulation.

Note: for G30/G31 gas, completely tighten the screw.

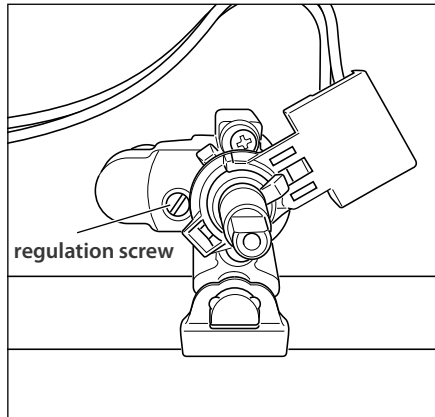

Fig. 15 Adjusting the minimum burner setting

20 Installation instructions

Table for the choice of the injectors

   Cat: II 2H3+

BURNERS	NOMINAL POWER [KW]	REDUCED POWER [KW]	G 30 - 28-30 mbar G 31 - 37 mbar	G 20 - 20 mbar
			Ø INJECTOR [1/100 mm]	Ø INJECTOR [1/100 mm]
AUXILIARY	1,00	0,30	50	72 (X)
SEMIRAPID	1,75	0,45	65	97 (Z)
RAPID	3,00	0,75	85	115 (Y)
TRIPLE-RING WOK	3,50	1,50	95	135 (T)

Lubrication of the gas taps

A qualified technician must lubricate the gas taps.

Important!

All intervention regarding installation maintenance and conversion of the appliance must be fulfilled with original factory parts.

The manufacturer declines any liability if these correct parts are not used.

Connecting the feeder cable

To connect the feeder cable to the cooker:

- Remove the screws securing the cover "A" on the rear of the cooker.
- Feed the supply cable through the cable clamp "D". See the 'Feeder cable section' following for the correct size for the cable.
- Connect the wires to the terminal block "B" as shown in the diagram; or connect the phase wires to the terminal block "B" and the earth wire to the terminal PE as shown.
- Take up any slack in the cable and secure with the cable clamp "D".
- Replace the cover "A".

N.B. The earth conductor must be left about 3 cm longer than the others.

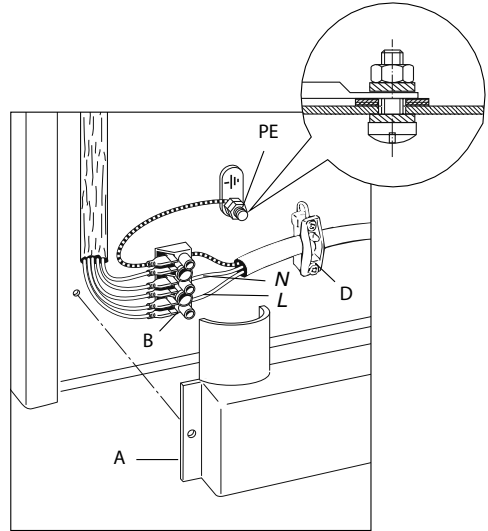

Figure 16a Connecting the feeder cable

Power Supply

230V - 50Hz 4500W 19,5A (230V)

Feeder cable section

"TYPE H05RR-F"

230V ~ 3 x 2.5 mm² (**)

(**) - Connection with wall box connection.

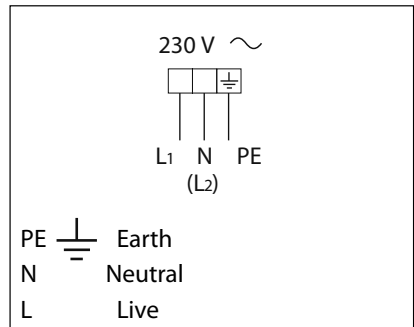

Figure 16b Connecting the feeder cable

22 Introducing your cooker

Thank you for buying a Fisher & Paykel freestanding cooker. Once it is installed and ready to use, you will want to know everything about it to make sure you get excellent results right from the start. This guide introduces you to all its special features. We recommend you read the whole guide before using your new cooker, for both safety and cooking success.

For more information, go to www.fisherpaykel.com

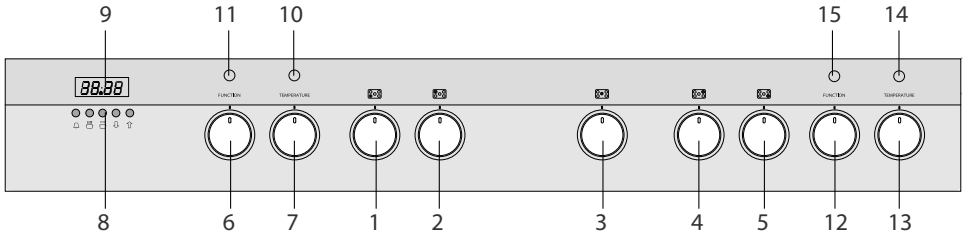

Figure 17 Cooker control panel

Gas cooktop controls:

- 1 Front left (rapid) burner control knob
- 2 Rear left (semi-rapid) burner control knob
- 3 Central (triple ring wok) burner control knob
- 4 Rear right (semi-rapid) burner control knob
- 5 Front right (auxiliary) burner control knob

Compact oven controls:

- 12 Function knob
- 13 Temperature knob
- 14 Temperature indicator light
- 15 Oven on light

Main oven controls:

- 6 Function knob
- 7 Temperature knob
- 8 Control buttons
- 9 Clock display
- 10 Temperature indicator light
- 11 Oven on indicator light

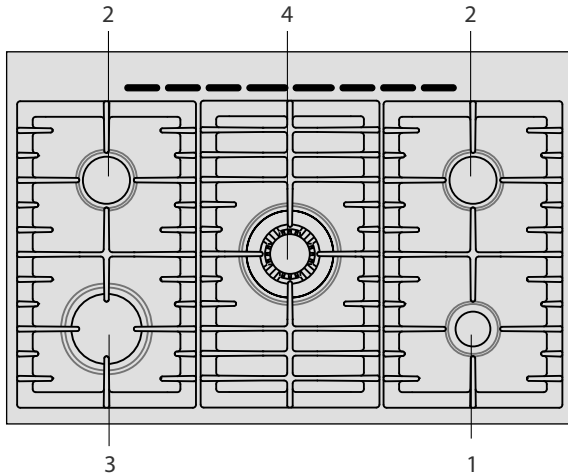

Figure 18 Cooktop layout

- 1 Auxillary burner
- 2 Semi-rapid burner
- 3 Rapid burner
- 4 Triple ring wok burner

Gas burners

The knob controls the flow of gas through the safety tap.

- ○ = closed valve
- ● = maximum aperture or flow
- ● = minimum aperture or flow

You can choose to cook at any heat between ● and ●, but never between ● and OFF.

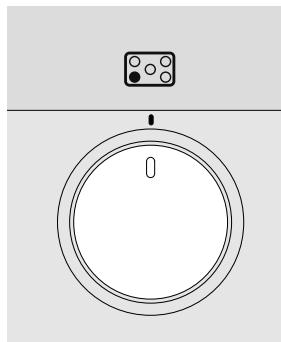





Figure 19 Burner control knob

Before using your cooktop

Before using your new cooktop, please:

- Read this user guide, taking special note of the safety and warnings section.
- Turn the cooker on.
- Make sure all controls are turned off.

Lighting the cooktop

- 1 Choose the control knob for the burner you want to use.
 - 2 Press the knob down gently and turn it anticlockwise to the  position. The ignitors on all the burners will spark.
Hold down the knob for approximately ten seconds after the burner has lit. Releasing the knob too soon will extinguish the flame.
 - 3 Adjust the flame anywhere between the  and  positions. Do not adjust the flame between  and OFF.
- Note: If the burner does not light within 15 seconds, turn the control knob off and wait at least one minute before trying again.

To switch the burner off, turn the knob clockwise until you hear the safety click.

After use, always turn the knobs to the off position.

Flame failure safety feature

The flame failure probe cuts off the gas supply to the burner if the flame is blown out.

When lighting the burner on flame failure models, hold down the knob for approximately ten seconds after the burner has lit. Releasing the knob too soon will extinguish the flame.

If the flames are accidentally extinguished, turn off the burner and do not try to light it again for at least one minute (to allow the gas to disperse).

If the cooktop does not light

If the cooktop does not light, check that:

- The cooker is switched on.
- The gas is turned on.
- You have held down the knob for at least ten seconds.
- The ignitors are sparking. If the ignitors are not sparking, they may be dirty or wet. Clean them with a toothbrush and methylated spirits, as shown.

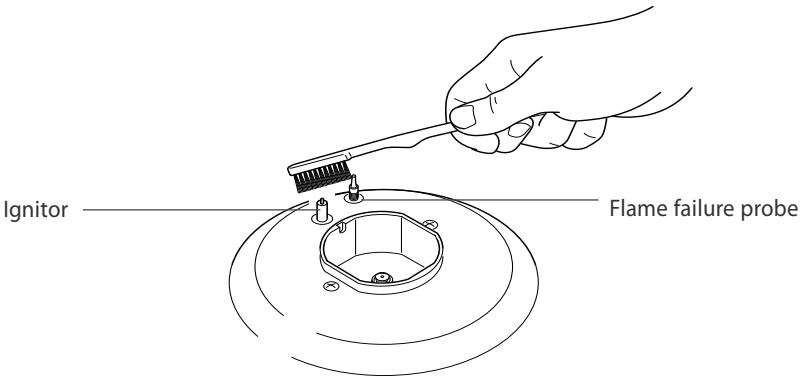

Figure 20 Cleaning the probe and ignitor

If the flame is irregular

If the flame is yellow or irregular, check that the burner parts, including the burner cap, are:

- Clean and dry.
- Positioned correctly. See 'Care and cleaning'.
- See also 'Troubleshooting'.

Using your gas cooktop

Choosing a burner

Use flat-bottomed pans, and make sure that they match your burner, as shown in the following table. A small pot on a large burner is not efficient.

Diameters of pans which may be used on the cooktop

Burners	Minimum	Maximum
Auxiliary	12 cm	14 cm
Semi-rapid	16 cm	24 cm
Rapid	24 cm	26 cm
Triple ring wok	26 cm	28 cm
Maximum diameter for woks 36 cm		

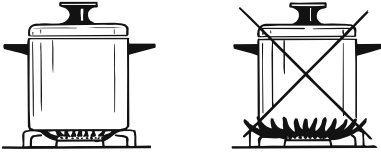

Figure 21a Correct and incorrect matching

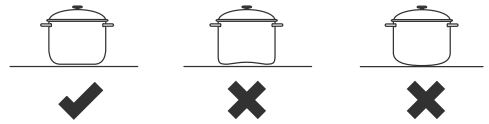

Figure 21b Efficient and inefficient saucepan bottoms

Wok stand

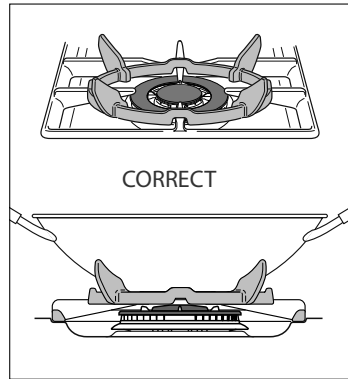
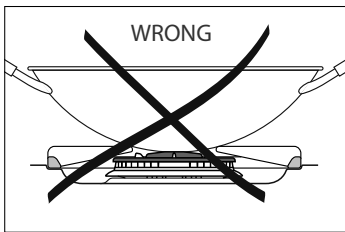

Figure 22 Correct placement of wok stand

Important!

- Using a wok without the stand may cause the burner to operate incorrectly.
- Do not use the stand for ordinary, flat-bottomed saucepans.
- The wok stand **MUST BE PLACED ONLY** over the pan support for the triple ring wok burner.
- The cooktop becomes very hot during operation. Keep children well out of reach.

Problem	Possible solutions
My cooktop burners do not light	<p>Check the cooker is switched on.</p> <p>Check the gas supply valve is turned on and the supply to the house is working. You should hear the gas when you turn a burner on.</p> <p>The ignitors may be dirty. Clean them with a toothbrush and methylated spirits.</p> <p>The burner parts may not be located properly. Check the assembly and make sure the burner cap is sitting flat.</p>
My burner flames are yellow or hard to start	<p>The burner parts may not be located properly. Check the assembly and make sure the burner cap is sitting flat.</p> <p>If you use bottled gas this may indicate you are getting near the end of the bottle.</p> <p>Check the burner parts are clean and dry.</p> <p>The gas pressure may not be at the correct level. Check with your service person or installer.</p> <p>Your cooker may not be set up for the gas you are using. Check this with your service person or installer.</p>
One of my burners has an uneven flame	<p>Check the burner parts are clean and dry. Check the assembly and make sure the burner cap is sitting flat.</p>
The flame goes out at low settings	<p>The gas supply pressure may be low. Check this with your service person or installer.</p> <p>The low setting may have been adjusted incorrectly. Check this with your service person or installer.</p>
My burners do not turn down much (when running on bottled gas or LPG)	<p>Your cooktop may not have been adjusted correctly. Check this with your service person or installer.</p>
The flame tips are very yellow	<p>Call your service person to service the cooker.</p>
There are objectionable odours	<p>Call your service person to service the cooker.</p>
The flame appears to lift off the burner	<p>Call your service person to service the cooker.</p>
There is an electricity failure	<p>If there is an electricity failure, you can still use your cooktop. Light the burners by holding a match close to the side of the burner and turning the control knob to the High position. Wait until the flame is burning evenly before adjusting.</p>

28 Using your main multifunction oven for the first time

Using your oven for the first time

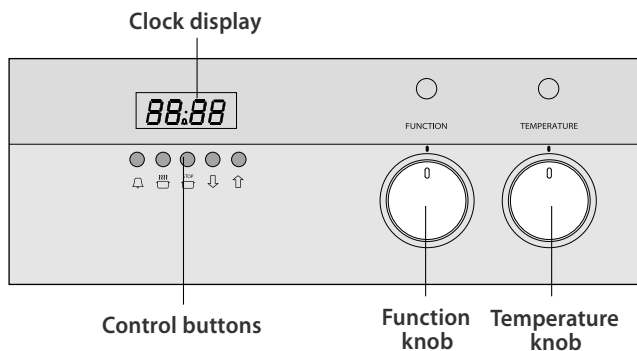





Figure 23 Main oven controls

Before using your new oven, please:

- 1 Read this user guide, taking special note of the 'Safety and warnings' section.
- 2 Remove all accessories and packaging.
- 3 Set the clock. The oven will not work until the clock has been set.
- 4 Condition the oven:
 - Put in the shelves and trays. Fit them between the metal runners, with the safety notch (which stops the tray sliding all the way out) facing down and the guard rail at the back. (If the shelf supports are not already fitted, see 'Care and cleaning' for how to do this).
 - Heat the oven on maximum for:
 - 60 minutes in the  position
 - 30 minutes in the  position
 - 15 minutes in the  position

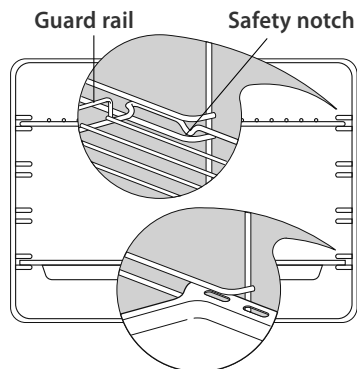







Figure 24 Correct position of shelves and pan

- 5 When the oven has cooled, switch it off at the wall. Wipe out the oven with a damp cloth and mild detergent, and dry thoroughly.

Buttons:

-  **Timer**
-  **Cooking time**
-  **End of cooking time**
-  **Decreases the number shown on the display or changes the volume of the beeps**
-  **Increases the number shown on the display**

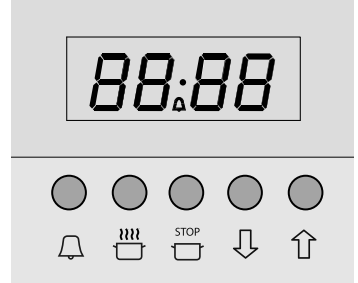







Figure 25 Clock display and control buttons





Illuminated symbols:



- A** - flashing - oven in automatic position but not set
- A** - steady illumination - oven set for automatic cooking
-  **Cooking taking place**
-  **Timer in operation**

Setting the clock

When first connected, or after a power failure, '0:00' will flash on the display. To set the clock, press the  and  buttons together and then the  and  buttons. Note: Changing the time will delete any automatic program.

Using the timer

- The timer can be set for up to 23 hours and 59 minutes.
- To set the timer, press the  button, then the  and  buttons.
 - To check the remaining time press the  button.
 - When the time is up, the timer will beep. Press the  button to turn it off.

Note: if 'A' is flashing on the display, press the  and  buttons together.

Setting the timer volume

You can select from three volume levels by pressing the  button.

Using your main oven

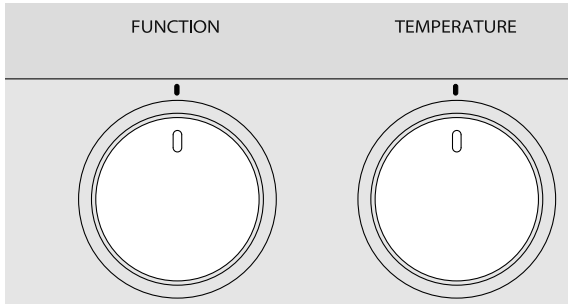



Figure 26 Function knob

Figure 27 Temperature knob

- 1 Select the function using the function knob. The oven light will come on.
- 2 Select the temperature using the temperature control knob. The oven temperature indicator light, above the temperature knob on the control panel, will glow until the oven has reached the set temperature, and then it will go out.
- 3 When you have finished cooking, turn the function and temperature control knobs to the off O position.

Note: if 'A' is flashing or steadily illuminated on the display, press the  and  buttons together.



OVEN LAMP

Only the oven light comes on. It remains on in all the cooking functions.



BAKE

The upper and lower heating elements come on. BAKE is the traditional method of cooking. It is best to cook on only one shelf at a time in this function.



GRILL

The grill at the top of the oven comes on. Preheat for two minutes. Use with the oven door closed and the temperature knob between 50° and max. 225°C. Do not grill for longer than 30 minutes at any one time.



DEFROST

Only the oven fan comes on. Use with the temperature knob set to O. The fan circulates air around the oven, speeding up the defrosting process by approximately 30%.

Note: this function is not for cooking food.



FAN FORCED

The circular heating element and the fan come on. The oven set on FAN FORCED can cook several different foods together. Use FAN FORCED for multi-shelf cooking.



FAN GRILL

Both the grill and the fan come on. Use with the oven door closed and the temperature knob between 50 °C and max. 200 °C. Do not grill for longer than 30 minutes at any one time.



WARM

The upper element, the circular element and the fan come on. Set between 50 °C and 140 °C.

Note: this function is not for cooking food.

**FAN BAKE (ENERGY SAVING)**

The upper and lower heating elements and the fan come on.

This function reduces the appliance's energy consumption. Ideal for gentle cooking over a longer period of time.

For best results, cook small portions on a single shelf and always use with the oven door closed. It is not necessary to preheat the oven.

Cooking times may be longer than standard functions. Do not use this function to preheat the oven for other functions.

Important!

Safe food handling: leave food in the oven for as short a time as possible before and after cooking or defrosting. This is to avoid contamination by organisms which may cause food poisoning. Take particular care during warmer weather.

Notes on baking and roasting:

- **Only use the fat filter for roasting. Remove before baking. Always clean the filter after cooking.**
- Preheat the oven before baking.
- Do not place anything, including water or ice, on the oven floor.

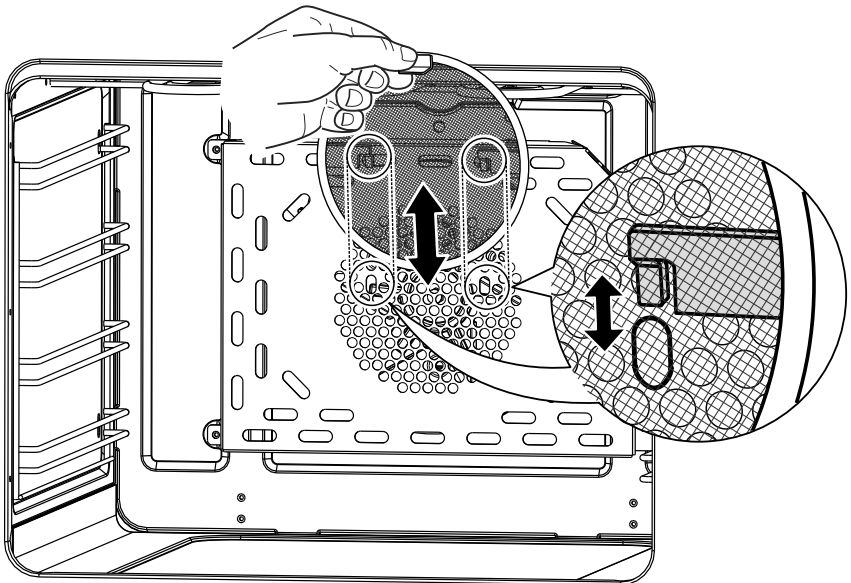









Figure 28 Fat filter





Use automatic cooking to automatically turn the oven on, cook, and then turn the oven off.

- 1 Check the clock shows the correct time.
- 2 Select the function and temperature. The oven will come on.
- 3 Decide how long the food will take to cook, allowing time for preheating if necessary.
- 4 Press the  button.  will show. Using the   buttons, set the cooking time.
- 5 Select the time you would like the oven to turn off by pressing the  button, and then using the   buttons.



If there is time to wait before cooking starts, the current time of day and A will show in the clock display. The oven temperature and function lights will go out and the oven will switch off but is now set for automatic cooking.

If you are already at home to turn the oven on and only want the oven to turn off automatically, start cooking as normal, then follow step 4 or step 5 to set a time to stop the oven.

When automatic cooking starts,  will be displayed and the oven will turn on.

- To see the remaining cook time, press the  button.
- To see the set stop time, press the  button.
- To cancel automatic cooking at any time, press the  and  buttons together and turn the temperature and function knobs to the off **O** position.

When the stop time is reached, the oven will turn off, the timer will beep and A will flash:



- To stop the beeping and return the oven to manual mode, press the  and  buttons together.
- Turn the temperature and function knobs to the off **O** position.

Important!

Safe food handling: leave food in the oven for as short a time as possible before and after cooking. This is to avoid contamination by organisms which may cause food poisoning. Take particular care during warmer weather.

Using your compact multifunction oven for the first time

Before using your new oven, please:

- 1 Read this user guide, taking special note of the 'Safety and warnings' section.
- 2 Remove all accessories and packaging.
- 3 Condition the oven:
 - Put in the shelf and tray. Fit them between the metal runners, with the safety notch (which stops the tray sliding all the way out) facing down and the guard rail at the back.
 - (If the shelf supports are not already fitted, see 'Care and cleaning' for how to do this).
 - Heat the oven on maximum for:
 - 60 minutes in the  position
 - 30 minutes in the  position
 - 15 minutes in the  position
- 4 When the oven has cooled, switch it off at the wall. Wipe out the oven with a damp cloth and mild detergent, and dry thoroughly.

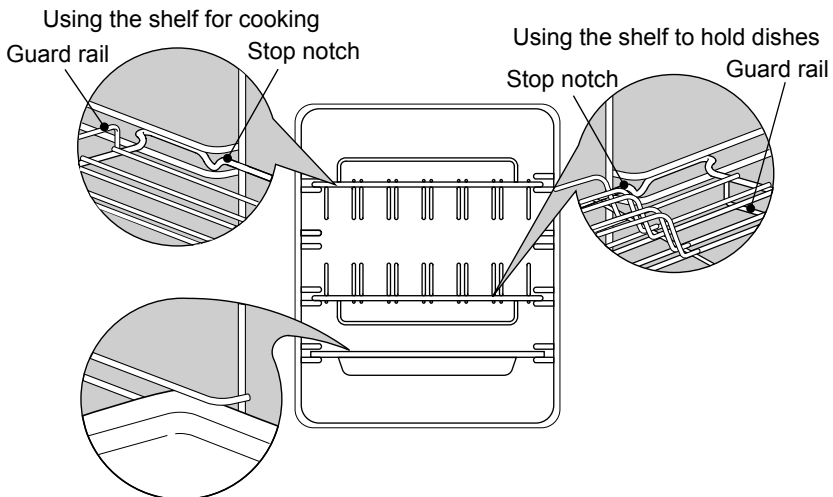

Figure 29 Correct position of shelf and pan

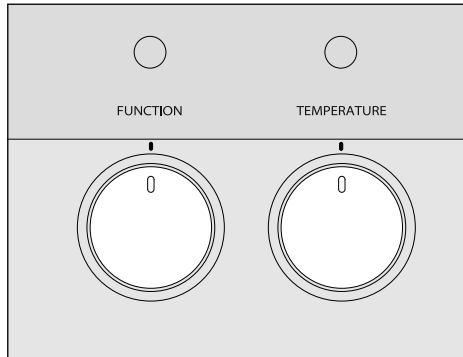

Figure 30 Compact oven function and temperature knobs

- 1 Select the function using the function knob. The oven light will come on.
- 2 Select the temperature using the temperature control knob. The oven temperature indicator light, above the temperature knob on the control panel, will glow until the oven has reached the set temperature, and then it will go out.
- 3 When you have finished cooking, turn the function and temperature control knobs to the off 0 position.

Cooking functions



OVEN LAMP

Only the oven light comes on. It remains on in all the cooking functions.



BAKE

The upper and lower heating elements come on. BAKE is the traditional method of cooking. It is best to cook on only one shelf at a time in this function.



GRILL

The grill at the top of the oven comes on. Preheat for two minutes. Use with the oven door closed and the temperature knob between 50° and max. 225°C. Do not grill for longer than 30 minutes at any one time.



DEFROST

Only the oven fan comes on. Use with the temperature knob set to 0. The fan circulates air around the oven, speeding up the defrosting process by approximately 30%.

Note: this function is not for cooking food.



FAN FORCED

The circular heating element and the fan come on. The oven set on FAN FORCED can cook several different foods together. Use FAN FORCED for multi-shelf cooking.



FAN GRILL

Both the grill and the fan come on. Use with the oven door closed and the temperature knob between 50 °C and max. 200 °C. Do not grill for longer than 30 minutes at any one time.



WARM

The upper element, the circular element and the fan come on. Set between 50 °C and 140 °C.

Note: this function is not for cooking food.



The upper and lower heating elements and the fan come on.

Important!

Safe food handling: leave food in the oven for as short a time as possible before and after cooking or defrosting. This is to avoid contamination by organisms which may cause food poisoning. Take particular care during warmer weather.

Notes on baking and roasting:

- Only use the fat filter for roasting. Remove before baking. Always clean the filter after cooking.
- Preheat the oven before baking.
- Do not place anything, including water or ice, on the oven floor.

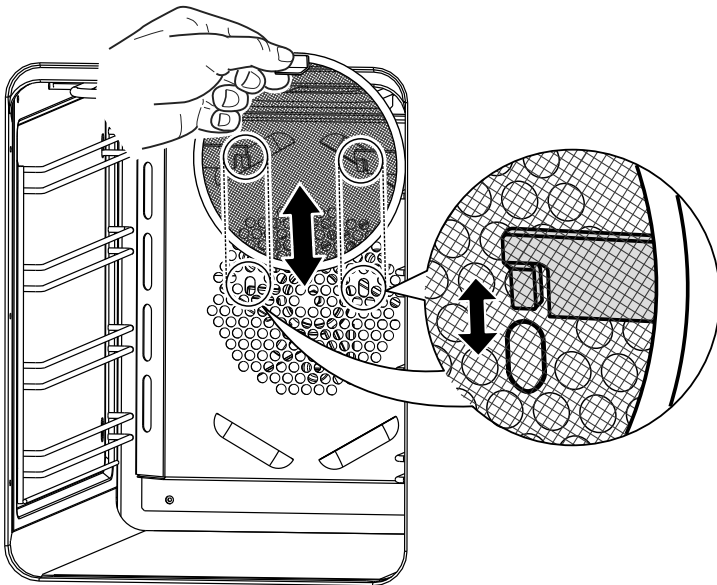

Figure 31 Compact oven fat filter.

Using the dish-warming shelf

The dish-warming shelf can be used to hold dishes or for cooking. If you want to warm plates, put the oven on bake at about 60 °C. Take care when removing plates, as they can get hot.

To use the shelf to hold dishes

- Turn it with the plate supports facing up.
- Fit the shelf between the metal runners on the lowest shelf support, with the safety stop notch down and at the back.

To use the shelf for cooking

- Turn the shelf with the plate supports facing down.
- Fit the shelf between the metal runners, with the other safety notch down and at the back.

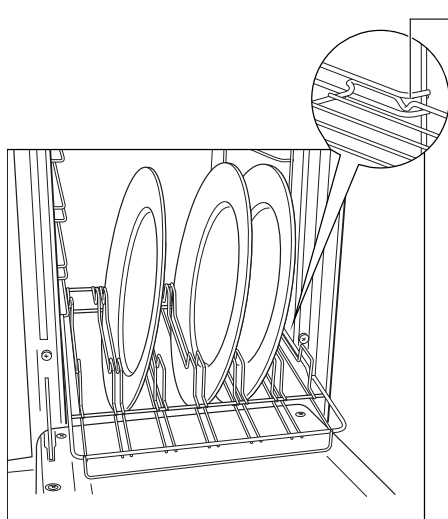

Figure 32a Using the shelf to hold dishes

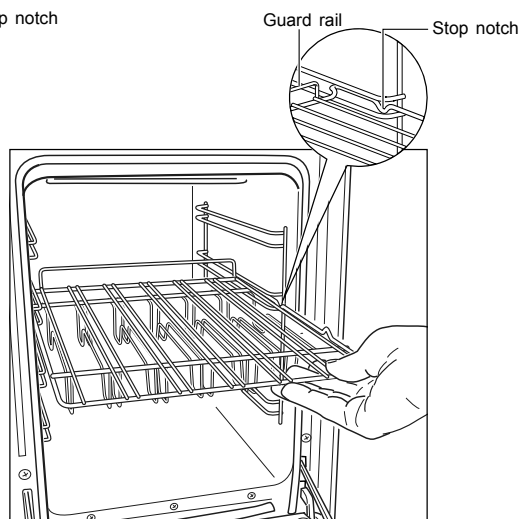
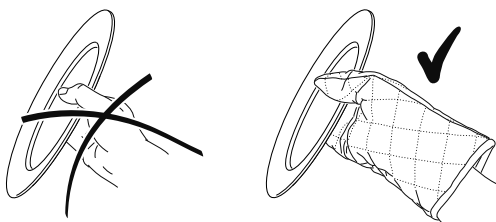

Figure 32b Using the shelf for cooking

Important!

Plates may become hot when warmed in the oven.

Always wear oven mitts to handle plates.



Important!

Before you start cleaning your cooker, please:

- *Read these cleaning instructions and the ‘Safety and warnings’ section at the start of this user guide.*
- *Turn the cooker off at the wall.*
- *Make sure the cooker is a safe temperature to touch.*
- *Do not use a steam cleaner.*
- *Do not keep flammable substances in the ovens or storage compartment.*

General advice

- Wipe out the ovens after every use.
- Wipe up spills. Avoid leaving alkaline or acidic substances (such as lemon juice or vinegar) on the oven surfaces.
- Do not use cleaning products with a chlorine or acidic base.

Cleaning the outside of the cooker

Important!

- *Do not use abrasive cleaners, cloths or pads on the outside surfaces.*
- *Immediately wipe off any caustic cleaners if they are spilled onto the oven door handles.*

Wipe the outside surfaces often, using warm water and a mild household detergent. The stainless steel may also be cleaned with a suitable cleaner and polish.

Note: if you choose to use a commercial stainless steel cleaner, please read the label to make sure it does not contain chlorine compounds as these are corrosive and may damage the appearance of your cooker.

Cleaning the gas cooktop

Maintenance Period	Description
Daily	• Clean gas cooktop as per following instructions.
Monthly	• Remove all burner parts, and clean using a non-abrasive detergent. Rinse in cold water, dry thoroughly, and replace. • Clean the ignitor and probe carefully, using a toothbrush and methylated spirits.
Every 3-4 years	• Contact your local authorized gas Service Agent to perform a thorough check on all gas components on the gas cooker.

Burner parts and pan supports

- You can remove and clean these parts with hot soapy water or non-abrasive detergents. Clean spills regularly before they become burnt on. Do not wash these parts in a dishwasher.
- After cleaning, check that the burners and their flame spreaders are dry before replacing correctly.
- It is very important to check that the burner flame spreader and the cap have been correctly positioned. Failure to do so can cause serious problems.
- Note: To avoid damage to the electric ignition do not try to light the cooktop when the burners are not in place.

Replacing the burners

Check that:

- The ignitor is always clean to ensure trouble-free sparking.
- The probe is always clean to ensure correct operation of the safety valves.

Note: both the ignitor and probe must be very carefully cleaned using a toothbrush and methylated spirits.

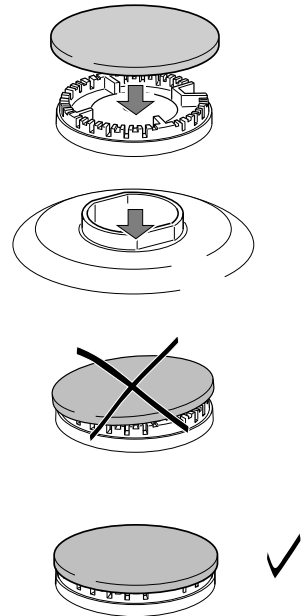
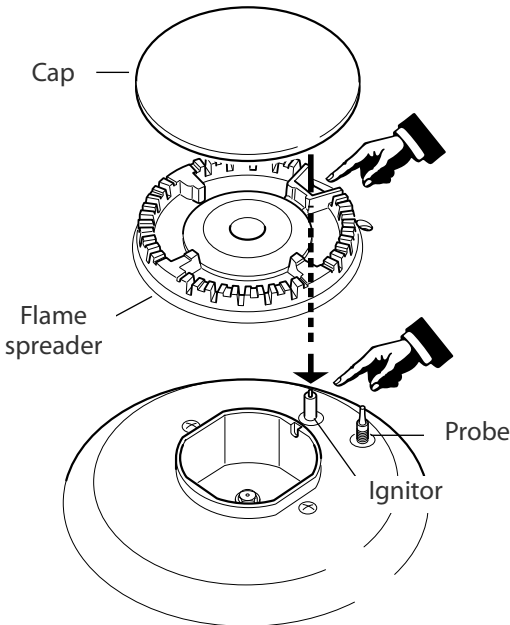

Figure 33 Auxiliary, rapid and semi-rapid burner parts

Figure 34 Replacing the auxiliary, rapid and semi-rapid burners

Replacing the triple ring wok burner

To replace the wok burner, fit the burner ring to the housing as shown by the arrow in the figure following. Make sure the burner is not able to rotate.

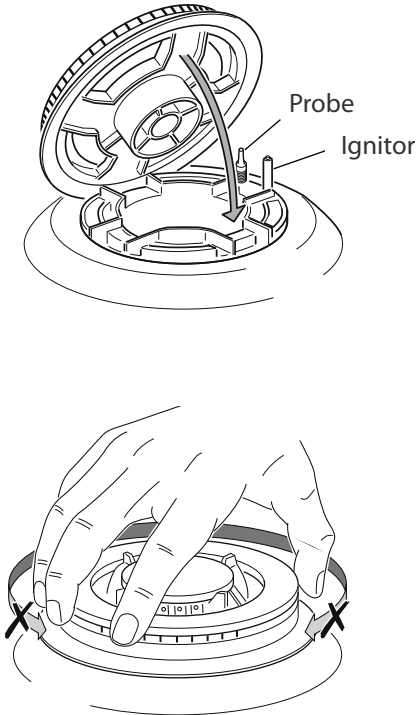

Figure 35 Triple ring wok burner parts

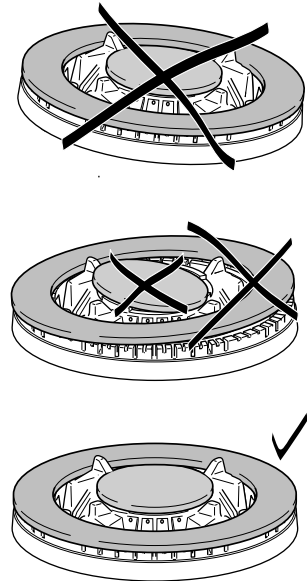

Figure 36 Replacing the triple ring wok burner

Gas taps

If you have problems with the gas taps, call your Authorised Service Centre.

Cleaning the inside of your ovens

- Clean the oven regularly and do not allow fats or oils to build up in the oven base or tray. Remove spillages as soon as they occur.
- Do not use abrasive cleaners, cloths or pads to clean the enamel.
- Do not use any oven cleaners, abrasive cleaners, ammonia-based cleaners, products containing acids or alkalis, or detergents on the catalytic panels (not supplied with all models).

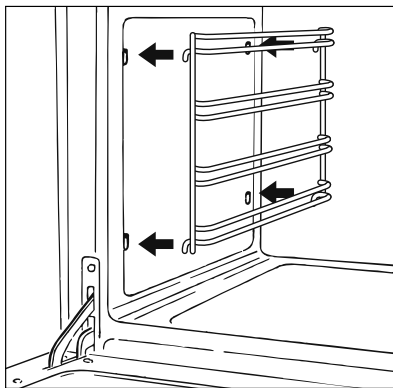

Fig.37 Removing the side racks

To make cleaning easier, you can remove the side racks, the oven door, and the fat filter. The grill element is self-cleaning.

Cleaning the enamel cavity

Clean the enamel on the inside of the oven when it has cooled down, using household detergents or an ammonia-based cleaner. You may use 'off the shelf' oven cleaners, if you carefully follow the manufacturers' instructions.

Cleaning the fat filter

Use only the supplied fat filter.

Clean the fat filter after every use. If the filter is not cleaned, it will block and shorten the life of the fan element. For normal soiling, place the filter in a dishwasher on normal wash. If the filter is very dirty, place in a saucepan with either two tablespoons of clothes washing powder, or one tablespoon of dishwashing powder. Bring to the boil and leave to soak for at least 30 minutes. Rinse the filter in clean water and dry.

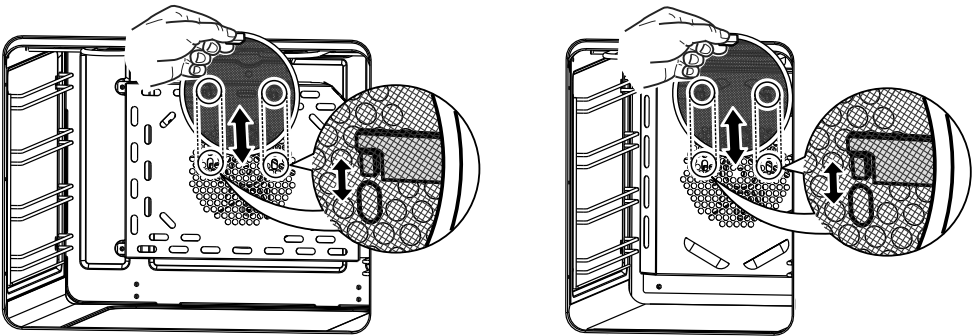

Fig.38 Fat filter

Note: the cooker is supplied with one fat filter, which may be used in either oven. As you cannot use it at the same time in both ovens, plan your cooking accordingly.

Storage compartment

The storage compartment is accessible through the pivoting panel.

Important!

Do not store flammable material in the ovens or in the storage compartment.

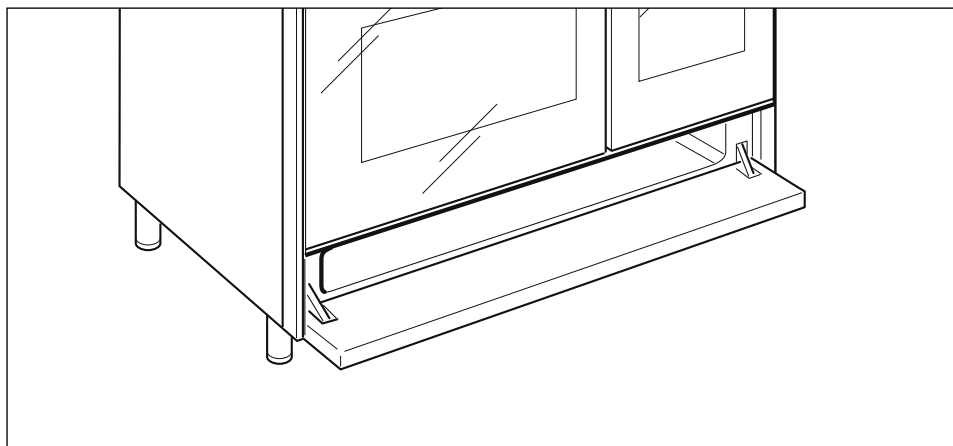

Fig.39 Storage compartment

Removing and refitting the oven door(s)

Important!

Take care, the oven door is heavy!

To remove the door

- 1 Open the door fully.

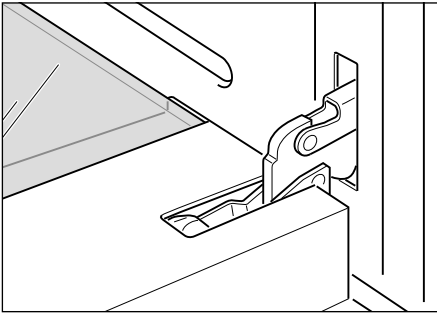

- 2 Open the levers.

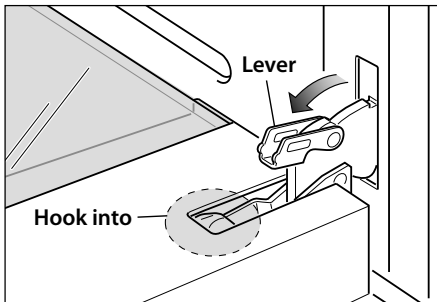

- 3 Hold the door.

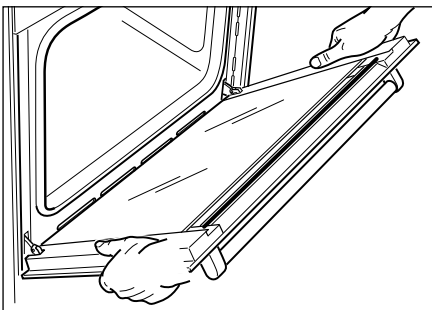

- 4 Close the door until the levers hook to it.

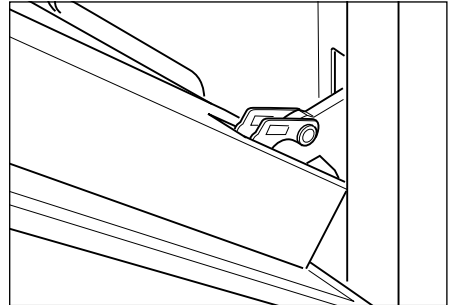

- 5 Disengage the hinges and remove the door.

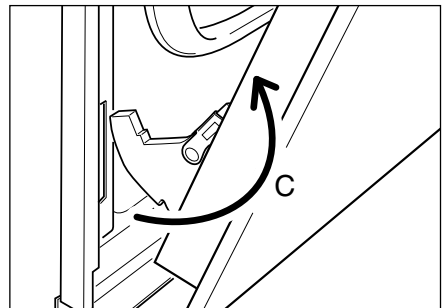

To refit the door

Repeat these steps in reverse order.

Important!

Always keep a safe distance from the door hinges, paying special attention to position of your hands. If the door hinges are not correctly hooked, they could unhook and close suddenly and unexpectedly with risk of injury.

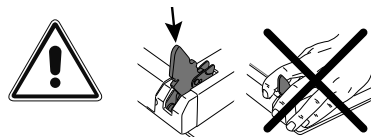

Cleaning the oven door glass

Do not use harsh abrasive cleaners, or sharp metal scrapers to clean the oven door glass as they scratch the surface and result in shattering of the glass.

Removing and refitting the inner glass panes of the oven door(s)

You may remove the inner glass pane for ease of cleaning.

Important!

- *The outer pane is not removable.*
- *Take care, the glass panes are heavy.*
- *Place the removed glass panes on a safe, soft surface.*

To remove the glass pane

1 Open the door fully.

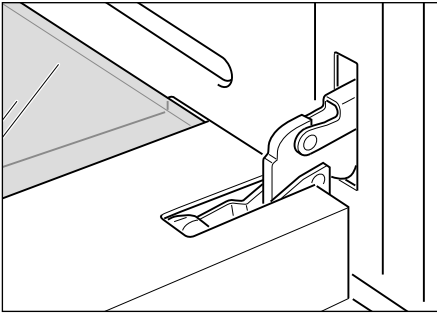

2 Open the levers.

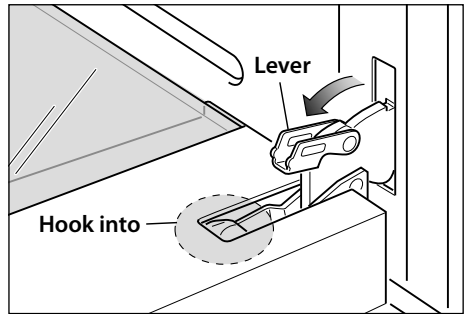

3 Close door until the levers hook to the door.

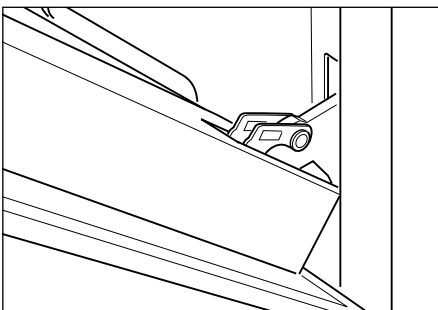

4 Slide out the inner pane.

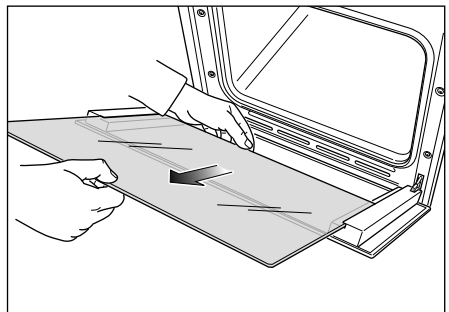

To refit the glass pane

- 1 Make sure the open levers firmly hook to the door.

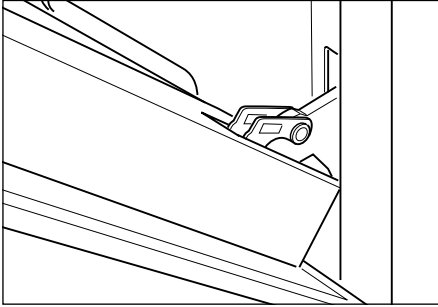

- 2 Check the rubber pads are in place.

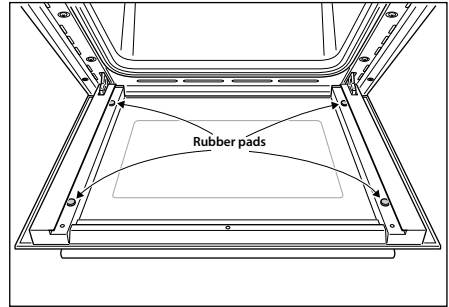

- 3 Check the pane is the right way around. The painted side faces toward the front of the door and the shiny side faces into the oven.

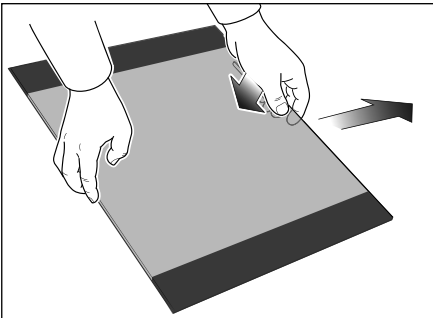

- 4 Insert the pane into the slide guides and slide it to the bottom retainers.

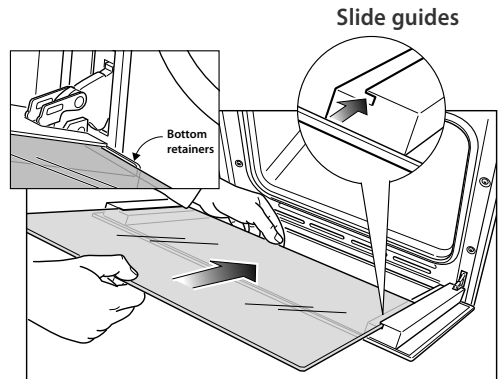

- 5 Open the door fully and close the levers.

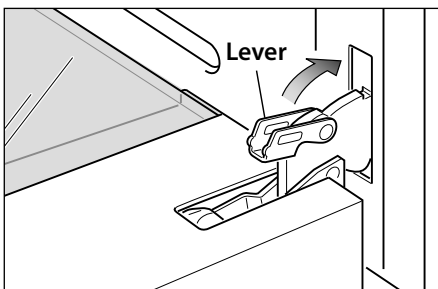

- 6 Note: The gap between the top edge of the inner glass pane and door is normal. This is part of the air circulation system.

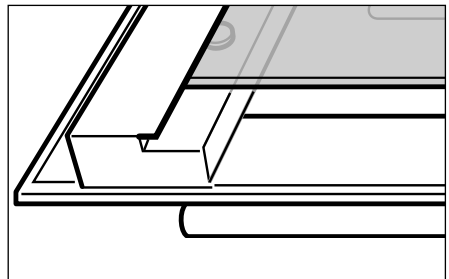

Replacing the halogen oven lamp

Important!

Disconnect the cooker from the power supply before continuing.

Let the oven cavity and the heating elements cool down.

- Remove the protective cover (A).
- Replace the halogen bulb (B) with a new one suitable for high temperatures (300°C) with the specifications: 220-240V, G9, and with the same wattage as the bulb being replaced (check wattage stamped on the bulb).

Important!

Never replace the halogen bulb with bare hands. Contamination from your fingers can cause premature failure. Always use a clean cloth or gloves.

- Refit the protective cover.
- Turn the power to the cooker back on and set the clock.

Note: Oven bulb replacement is not covered by your warranty.

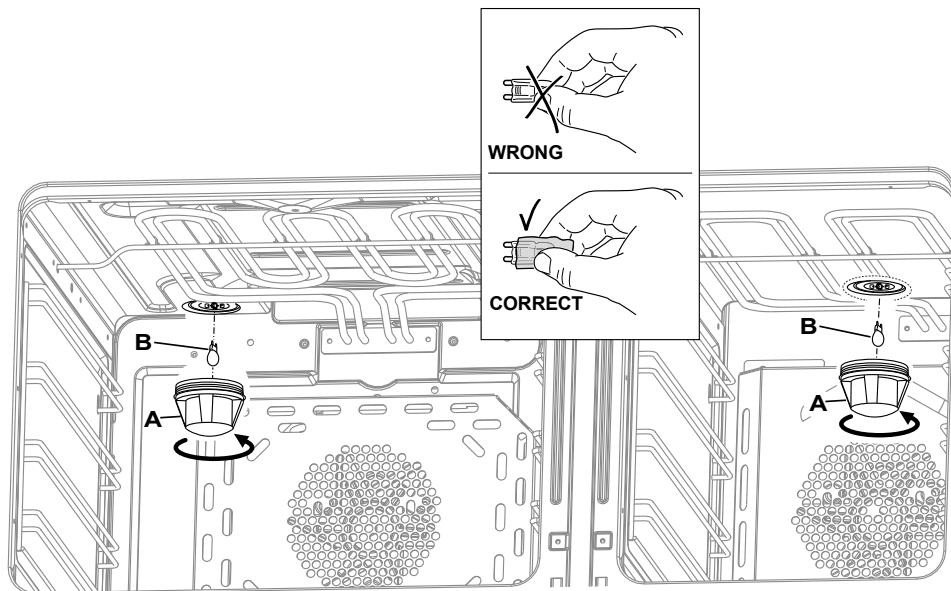

Fig.40 Removing either oven lamp

Before you call for service or assistance ...

Check the things you can do yourself. Refer to the installation instructions and your user guide and check that:

- 1 Your product is correctly installed.
- 2 You are familiar with its normal operation.

If after checking these points you still need assistance, please refer to the Service & Warranty book for warranty details and your nearest Authorised Service Centre, or contact us through our website:

www.fisherpaykel.com

This cooker has been designed and constructed in accordance with the following codes and specifications:

In Europe:

Safety requirements of EEC "Gas" Regulation (EU) 2016/426:

- EN 30-1-1
- EN 30-2-1
- EN 437



Safety requirements of EEC Directive "Low voltage" 2014/35/EU:

- EN 60335-1 General Requirements for Domestic electrical appliances
- EN 60335-2-6 Particular Requirements for Domestic electrical cooking appliances

Safety requirements of EEC Directive "EMCD" 2014/30/EU:

- EN 55014-1, EN 55014-2, EN 61000-3-2, EN 61000-3-3 Electromagnetic Compatibility Requirements

Requirements of EEC Directive 93/68/EEC and 2011/65/EU.

European directive 2012/19/EU on Waste Electrical and Electronic Equipment (WEEE)
(for European Union countries only)

GB This appliance is marked according to the European directive 2012/19/EU on Waste Electrical and Electronic Equipment (WEEE). By ensuring this product is disposed of correctly, you will help prevent potential negative consequences for the environment and human health, which could otherwise be caused by inappropriate waste handling of this product.

The symbol  on the product, or on the documents accompanying the product, indicates that this appliance may not be treated as household waste. Instead it shall be handed over to the applicable collection point for the recycling of electrical and electronic equipment. Disposal must be carried out in accordance with local environmental regulations for waste disposal. For more detailed information about treatment, recovery and recycling of this product, please contact your local city office, your household waste disposal service or the shop where you purchased the product.

FISHERPAYKEL.COM

© Fisher & Paykel Appliances 2019. All rights reserved.

The product specifications in this booklet apply to the specific products and models described at the date of issue. Under our policy of continuous product improvement, these specifications may change at any time. You should therefore check with your Dealer to ensure this booklet correctly describes the product currently available.

GB IE

590604E / 1105903-β0 04.19