



# PRESTIGE PRO<sup>®</sup> SERIES

## Owner's Manual

PRO500, PRO665 & PRO825

Grills illustrated in this manual may differ from model purchased.

**We Want Your Feedback!**

Visit [Napoleon.com](http://Napoleon.com) to write a review



Apply Serial Number



# CONGRATULATIONS ON YOUR NAPOLEON GRILL!

You've Just Upgraded Your Grilling Game.

**WE WANT YOUR GRILLING EXPERIENCE TO BE MEMORABLE AND SAFE.**

**Please read and follow this Owner's Manual before using your grill to avoid property damage, personal injury, or death.**

**Remove all packaging material, promotional labels and cards from the grill before use.**

**USE OUTDOORS IN A WELL-VENTILATED SPACE.**

**DO NOT OPERATE IN A BUILDING, GARAGE, OR ANY OTHER ENCLOSED AREA.**

## **DANGER!**

### **IF YOU SMELL GAS:**

- Shut off gas to the appliance
- Extinguish any open flame
- Open lid
- If odor continues, keep away from the appliance and immediately call your gas supplier, or fire department.



## **WARNING!**

Do not try to light this appliance without reading the "LIGHTING" instructions section of this manual.

Do not store or use gasoline, or other flammable liquids or vapors in the vicinity of this or any other appliance.

An L.P. (propane) cylinder not connected for use must not be stored in the vicinity of this or any other appliance.

If the information in these instructions is not followed exactly, a fire or explosion may result and cause property damage, personal injury, or death.



**Alert adults and children about the hazard of hot surface temperatures. Supervise young children near the grill.**

**NOTICE TO INSTALLER: Leave these instructions with the grill owner for future reference.**

**NOTICE TO CONSUMER: Keep these instructions for future reference.**

# Welcome to Napoleon!

## SAFETY FIRST



### WARNING! General Information.

This grill should be installed in conformity with local codes.

If a rotisserie motor is used, it must be electrically grounded in accordance with local codes.



### WARNING! Electrical Precautions

Keep all electrical supply cords and fuel supply hoses away from all heated surfaces.

First connect all electrical components to appliance, then plug into outlet. Use only a Ground Fault Interrupter (GFI) protected circuit with this outdoor cooking appliance.

Never remove the grounding plug. Use only extension cords that have been rated for the power of the equipment and approved for outdoor use with W-A marking.

Electrical Rating: 230 - 240V / AC - 50HZ - 0.4A.



### WARNING! Installation & Assembly

Assemble this grill exactly as instructed in the Assembly Guide. If the grill was assembled in-store, review the assembly instructions to ensure it is done correctly.

Not to be installed in or on recreational vehicles and/or boats.

Perform the required Leak Test before operating the grill.

Do not modify this grill under any circumstances.

Do not use a cylinder that is not equipped with the appropriate type connection.

Only use the pressure regulator and hose assembly supplied with this grill or replacement parts specifically recommended by Napoleon.



### WARNING! Operation

Read this entire Owner's Manual before operating this grill.

Leak Test this grill before each use, annually and when any gas components are replaced.

Follow the lighting instructions carefully.



### WARNING! Storage & Disuse

Turn off gas at the propane cylinder supply valve.

Disconnect the hose between the propane cylinder and grill.

Remove the propane cylinder and store outdoors in a well-ventilated space away from children.

DO NOT store propane cylinders in a building, garage, shed, or any other enclosed space.



### WARNING! Correct Product Disposal

This marking indicates that this product should not be disposed with other household wastes throughout the EU. To prevent possible harm to the environment or human health from uncontrolled waste disposal, recycle it responsibly to promote the sustainable reuse of material resources. To return your used device, please use the return and collection systems or contact the retailer where the product was purchased. They can take this product for environmental safe recycling.

## CONTENTS

Welcome to Napoleon!	3
Safety First	
Full System Features	4
Getting Started	5
Leak Test	
Operation	9
Lighting your grill	
Grilling Instructions	
How to use the Rear Burner & Rotisserie	
Illumination Instructions	
The Grilling Experience Checklist	
How to season cast iron cooking grids	
Infrared Grilling Guide	15
Cleaning Instructions	16
Maintenance Instructions	19
Combustion in air adjustment	
Stainless in harsh environments	
Troubleshooting	22
Diagram for Electrical Connections	
Warranty	28



# Full System Features

Dual-level Stainless Steel Sear Plates for consistent even heating and vaporizing drippings for more flavourful food

Rear Infrared Rotisserie Burner to enjoy succulent rotisserie meals

Interior Lights for late night entertaining

Two Stage power side burner for limitless cooking

**LED SPECTRUM NIGHT LIGHT™** Control Knobs with safety glow

Instant **JETFIRE™** Ignition for quick and east start-up

Easy Locking Casters safely lock the grill in position

Integrated Wood Chip Smoker Tray to enhance flavor

Stainless Steel Iconic **WAVE™** Cooking Grids for those distinctive sear marks and even cooking

Large Stainless Steel Warming Rack for increased cooking area

**ACCU-PROBE™** Temperature Gauge to easily read the temperature for perfect results

Integrated Ice and Marinade Bucket with Cutting Board and Tool Hooks

Dedicated Infrared **SIZZLE ZONE™** bottom burners for perfectly grilled steaks

Easy access drip pan for efficient maintenance

Heavy Gauge Stainless Steel Burners for long lasting quality

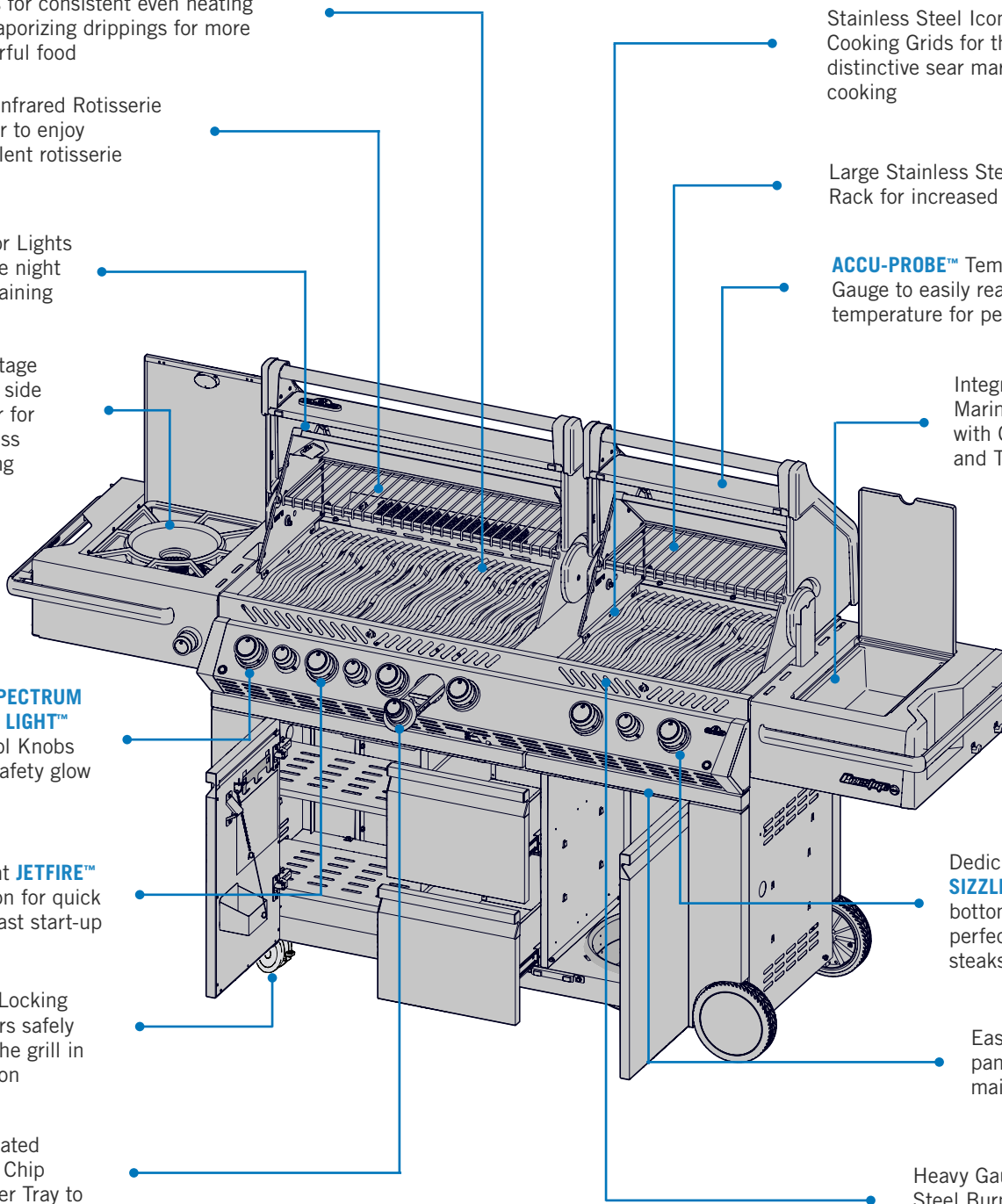

The grills illustrated in this Owner's Manual may differ from the model you purchased. Featured model: PRESTIGE PR0825

# Getting Started



**DANGER / WARNING!** Advises of a hazard that could result in a fire, explosion, death or serious physical injury.



**WARNING / CAUTION!** Advises of a hazard that could result in minor physical injury or property damage.



Wear protective gloves.



Wear safety glasses.



**CAUTION!** Hot surface.



Important information.



Do not smoke while performing a gas leak test. Sparks or flames will cause a fire, explosion, damage to property, serious physical injury, or death.



Never use an open flame to check for gas leaks. Sparks or flames will cause a fire, explosion, damage to property, serious physical injury, or death.



**DANGER!** Immediately shut off the gas supply and disconnect.

## ADDITIONAL SAFE OPERATING PRACTICES

- Do not route the hose underneath the drip pan. Maintain proper hose clearance to the bottom of the unit.
- Ensure sear plates are positioned properly according to sear plate installation instructions.
- Burner controls must be off when turning the gas cylinder valve on.
- Do not light burners with the lid closed.
- Do not operate the rear burner(s) with the main burners.
- Do not close the side burner lid when operating or hot.
- Do not deep fry food on the side burner.
- Do not adjust the cooking grids when operating or hot.
- Do not move the appliance during use.
- Turn off the gas supply at the source after use.
- Do not modify the appliance.
- Maintenance should only be done when the grill is cool.
- Do not store lighters, matches or any other combustibles inside the enclosure or condiment tray.
- Keep all electrical supply cords and fuel supply hoses away from all heated surfaces.
- Clean the grease tray, drip pan, and sear plates regularly to avoid build-up and grease fires.
- Keep the infrared burner and main burner venturi tubes free from spider webs and other obstructions by inspecting and cleaning it regularly.
- Do not allow cold water (rain, sprinkler, hose etc.) to contact the heated grill. An immediate temperature change will chip the porcelain and crack the ceramic burners.
- Do not use a pressure washer to clean any part of the grill.
- Do not locate this grill where it can be exposed to high winds, especially when the wind can come from directly behind the grill.
- Do not operate appliance under any combustible construction.
- Never cover more than 75% of the cooking surface with solid metal.
- This appliance must be kept away from flammable materials while in use.
- Always maintain proper clearance to combustibles 24" (610mm) to rear of unit, 7" (178mm) to sides.
- Appliance PRO500 must always maintain proper clearance to combustibles 20" (508mm) to rear of unit, 7" (178mm) to sides.
- Appliance PRO665 and PRO825 must always maintain proper clearance to combustibles 27" (686mm) to rear of unit, 7" (178mm) to sides.
- Additional clearance of 24" (610mm) is recommended near vinyl siding or panes of glass.

**CAUTION!** The hook-up and installation of the gas and hose connection must be performed by a licensed gas fitter, and leak tested before operating the grill.

**CAUTION!** Ensure the hoses do not contact any high temperature surfaces of the grill.

**WARNING!** Accessible parts may be very hot. Keep young children away.



## GAS CONNECTIONS

### Option 1: To a Gas Cylinder

Use a propane cylinder of minimum 6 kg or a butane cylinder of 13 kg constructed and marked in accordance with national and regional codes. Ensure that the cylinder can provide enough fuel to operate the appliance. If in doubt, check with your local gas supplier.

Use a gas pressure regulator and hose supplied by Napoleon; if not included, use a regulator and hose that meet national and regional codes. The recommended length of the hose is 0.9 m. The hose must never be longer than 1.5 m.

**Note:** The hose should be replaced before the expiry date printed on it.

Only place cylinders within the maximum width and height dimensions inside the enclosure on the bottom shelf. Cylinders that surpass the maximum dimensions must be placed outside the enclosure on level ground. Refer to the diagram below for specific measurements.

### Hook-up and Installation

- Check the cylinder for dents or rust, and have it inspected by your gas supplier.
- Never use a cylinder with a damaged valve.
- Place the cylinder in its designated area on the bottom shelf.
- Ensure the gas regulator hose has no twists or kinks.
- Remove the cap or plug from the cylinder fuel valve.
- Tighten the regulator to the cylinder valve.
- Ensure the hose does not contact with the drip pan or any high temperature surfaces of the grill because it will melt and cause a fire.
- Ensure the cylinder is not left exposed to extreme heat or direct sunlight.
- Leak test all joints prior to operating the grill. See “Leak Test”.

### Maximum Cylinder Dimensions

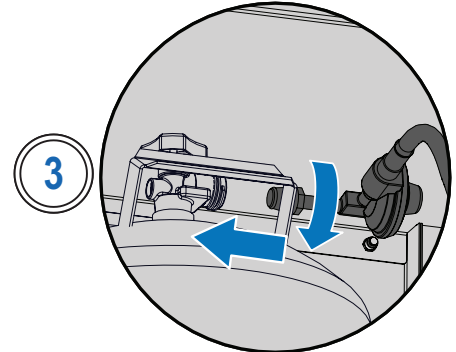
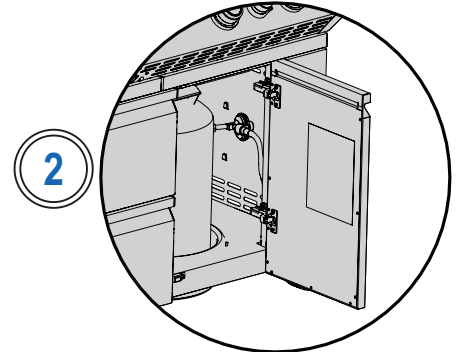
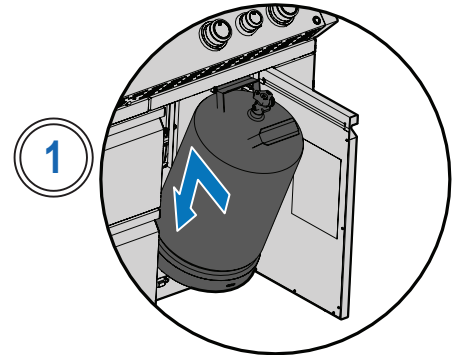
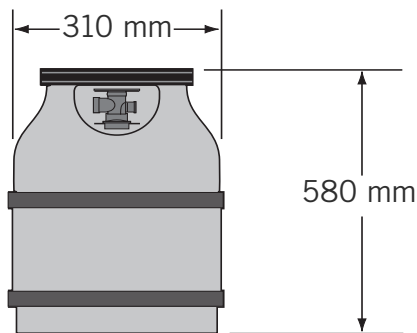

**WARNING!** Do not store a spare gas cylinder below the grill head or side burners.

**WARNING!** Never use a gas cylinder that is beyond 80% full.

**WARNING!** Follow all specifications and instructions exactly to prevent fire, explosion, property damage, personal injury, or death.

**WARNING!** Disconnect the grill and its individual shutoff valve from the gas supply piping system during any pressure testing in excess of ½ psi (3.5 kPa).

**WARNING!** Close the individual shutoff valve to isolate the grill from the gas supply piping system during any pressure testing equal to or less than ½ Psi (3.5 kPa).



## Technical Data

The following table lists gross heat input, gas usage values and orifice sizes corresponding to each burner per Gas Category:

		ORIFICE SIZE		GROSS HEAT INPUT (TOTAL)		GAS USAGE (TOTAL)	
		I	II	I	II	I	II
PR0500	MAIN FLAME	#60	1.45mm	16 kW	14 kW	1164 g/hr	1334 L/hr
	REAR	1.25mm	#50	5.7kW	5 kW	415 g/hr	476 L/hr
	SIDE FLAME	#60	1.45mm	4 kW	3.5 kW	291 g/hr	333 L/hr
	SIDE INFRARED	#60	1.45mm	4 kW	3.5 kW	291 g/hr	333 L/hr
PR0665	MAIN FLAME	#60	1.45mm	19 kW		1383 g/hr	1810 L/hr
	REAR	1.25mm	#50	5.5 kW		400 g/hr	524 L/hr
	SIDE INFRARED	#58	1/16"	4 kW		291 g/hr	381 L/hr
	SMOKER	#67	#56	2.5 kW		182 g/hr	238 L/hr
PR0825	MAIN FLAME	#60	-	15.2 kW	-	1106 g/hr	-
	MAIN INFRARED	#60	-	7.6 kW	-	553 g/hr	-
	REAR	1.25mm	-	5.5 kW	-	400 g/hr	-
	SIDE FLAME	#76 / 1.1mm	-	5.3 kW	-	386 g/hr	-
	SMOKER	#67	-	2.5 kW	-	182 g/hr	-
	WARMING	#67	-	2.5 kW	-	182 g/hr	-

The following table lists all certified gases and pressures. Verify the information on the rating plate corresponds with this list.

**Note:** Only use regulators that supply the pressure listed here.

Gas Category	I <sub>3B/P(30)</sub>	I <sub>3+(28-30/37)</sub>	I <sub>3B/P(37)</sub>	I <sub>3B/P(50)</sub>	II <sub>2H</sub>	II <sub>2E</sub>	II <sub>2E+</sub>	II <sub>2L</sub>
Orifice Sizes	I	I	I	I	II	II	II	II
Gases / Pressures	Butane / Propane 30mbar	Butane 28-30mbar Propane 37mbar	Butane / Propane 37mbar	Butane / Propane 50mbar	G20 at 20mbar	G20 at 20/25 mbar	G20/G25 at 20/25 mbar	G25 at 25mbar
Countries	AL, BE, BG, CY, CZ, DK, EE, FI, FR, GB, GR, HR, HU, IS, IT, LT, LU, MT, NL, NO, RO, SE, SI, SK, TR	BE, CH, CY, CZ, ES, FR, GB, GR, IE, IT, LT, LU, LV, PT, SI, SK, TR	BE, CH, CZ, ES, FR, GB, GR, HR, HU, IE, IT, LT, NL, PL, PT, RO, SI, SK, TR	AT, CH, CZ, DE, SK	AT, BG, CH, CZ, DK, EE, ES, FI, GB, GR, HR, HU, IE, IS, IT, LV, LT, NO, PT, RO, SE, SI, SK, TR	DE, LU, PL	BE,FR	NL

**WARNING!** Check the hose for evidence of excessive abrasion, melting, cuts or cracks. If the hose is damaged, it must be replaced with an assembly specifically recommended by Napoleon.



## LEAK TEST

### Why and When to Leak Test?

A leak test confirms no gas is escaping after you connect the hose to the gas supply.

Each time the tank is refilled and reinstalled, ensure that there are no leaks in the fitting where the regulator connects to the tank.

Leak test this grill before use, annually, and when any gas components are replaced.

### Leak Test Steps

1. Do not smoke while performing the test.
2. Remove all sources of ignition.
3. Turn all burner controls to the off position.
4. Turn the gas supply valve on.
5. Brush a half-and-half solution liquid soap and water onto all joints and connections of the regulator, hose, manifolds, and valves.
6. Bubbles indicate a gas leak.

### If you find a leak

1. Tighten any loose joints.
2. If the leak cannot be stopped, immediately shut off the gas supply and disconnect the grill.
3. Have the grill inspected by a certified installer, or dealer.
4. Do not use the grill until the leak has been fixed.

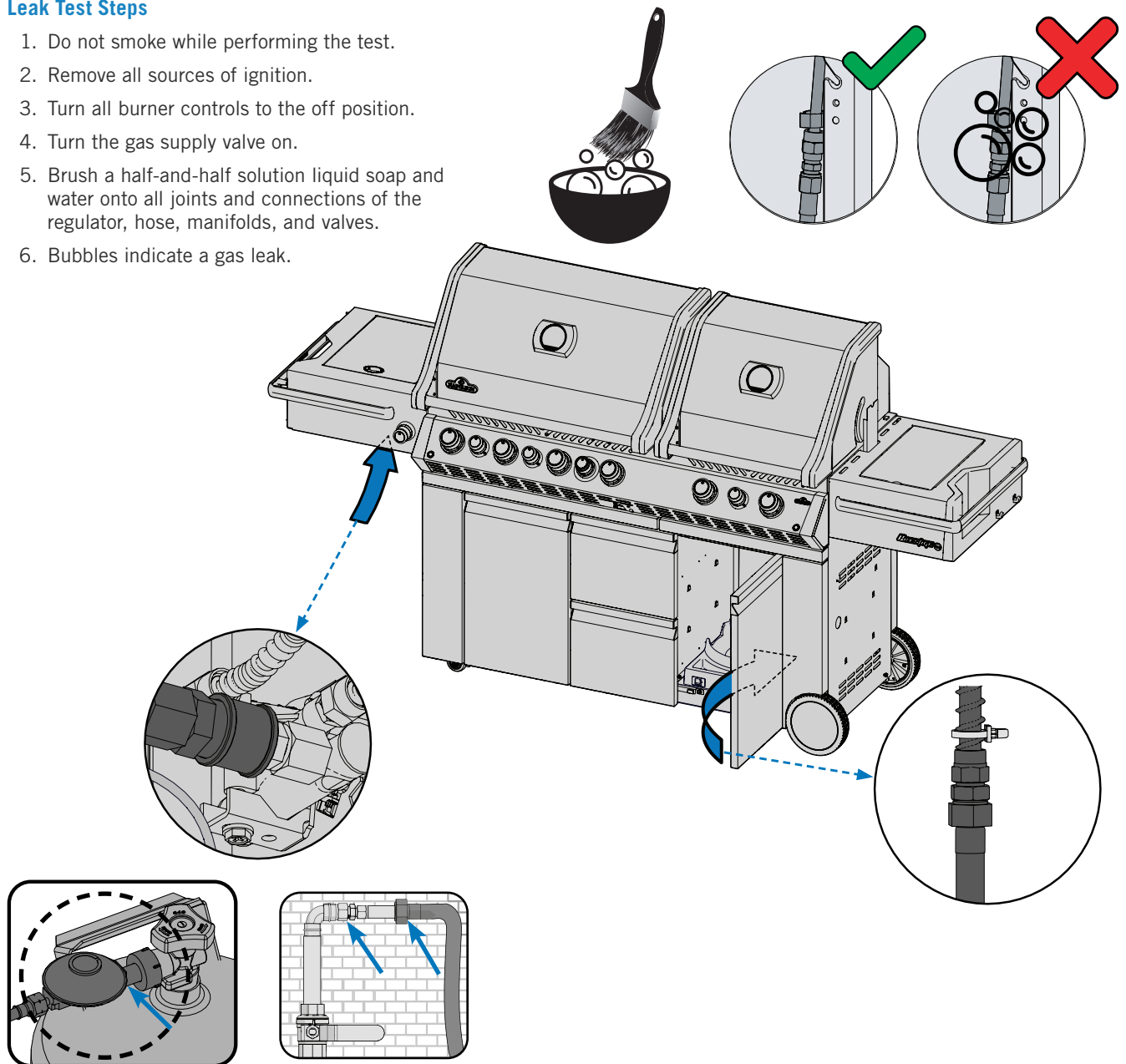

**WARNING!** Never use an open flame to check for gas leaks. Sparks or flames will cause a fire, explosion, damage to property, serious physical injury, or death.

**WARNING!** Only use the pressure regulator and hose assembly supplied with the grill, or one in conformity with local codes.



# Operation

## LIGHTING YOUR GRILL

### Is it the very first time? Perform a Burn-off

Remove warming rack and run the main burners on high for 30 minutes. It is normal for the grill to emit an odor the first time it is lit. This odor is caused by the “burn-off” of internal paints and lubricants used in the manufacturing process and will not occur again.

**WARNING!** Do not operate the rear or side burner while performing a Burn-Off.



### Main Burner Lighting

1. Open grill lid.
2. Push and slowly turn any main burner knob counter clockwise to HIGH position until pilot lights. Continue to push down on the control knob until the burner lights and then release.
3. If the pilot does not light – immediately turn the control knob clockwise to the OFF position. Repeat step 2.
4. If the pilot and burner will not light in 5 seconds – turn the control knob clockwise to the OFF position. Wait 5 minutes for gas to dissipate. Repeat steps 2 and 3, or light with a match. (Fig. 1).

**WARNING!** Do not use the rear burner while operating the main burner.



### Rear Burner Lighting (if equipped)

1. Open grill lid.
2. Remove warming rack.
3. Push and slowly turn rear burner knob counter clockwise to HIGH position.
4. Press and hold igniter button until the burner lights, or light by match.
5. If the burner will not light – turn burner control knob clockwise to the OFF position. Wait 5 minutes. Repeat step 3 and 4. (Fig. 1)

### Side Burner Lighting (if equipped)

1. Open burner cover.
2. Push and slowly turn side burner knob counter clockwise to HIGH position.
3. Press and hold igniter button until the burner lights, or light by match.
4. If the burner will not ignite – turn burner control knob clockwise to the OFF position. Wait 5 minutes. Repeat step 2 and 3. (Fig. 2)

### Lighting with a match

1. Clip the match into the supplied lighting rod.
2. Insert the lit match through the cooking grids and sear plates
3. While turning the corresponding burner knob to high. (Fig. 3)



**WARNING!** Ensure all burner controls are in the OFF position before slowly turning on gas supply valve.

**WARNING!** Follow the lighting instructions carefully.

**WARNING!** Make sure the lid of the grill is OPEN while igniting.

**WARNING!** Do not adjust the cooking grids while the grill is hot, or operating.

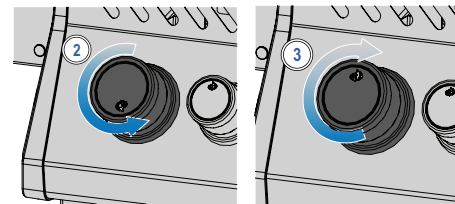
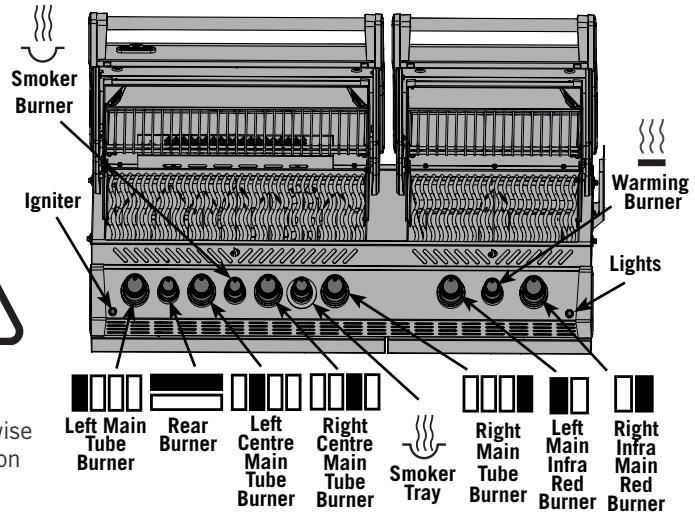

Fig. 1

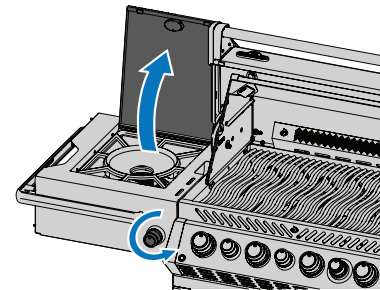

Fig. 2

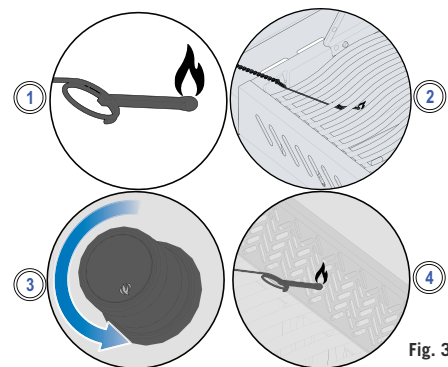

Fig. 3

## GRILLING INSTRUCTIONS

### Main Burner Use

- Preheat the grill before searing food by operating all main burners on high with the lid closed for approximately 10 minutes.
- Food cooked for only a short time such as fish and vegetables can be grilled with the lid open.
- Grilling with the lid closed ensures higher and consistent temperatures that cook meat more evenly and can reduce cooking times.
- The cooking grids can be oiled before preheating to reduce sticking when grilling lean meat such as chicken breast, or pork.
- Food that takes longer than 30 minutes such as roasts can be cooked indirectly with the burner lit opposite the food. See Indirect Grilling.
- Trim excess fat off meat to prevent flare-ups, or reduce the temperature of the grill.
- Flare ups – move food away from the flames and reduce the heat. Leave the lid open.

### Direct Grilling

This method is often used for searing, or food cooked for only a short time such as hamburgers, steaks, chicken, or vegetables.

Place food on the cooking grids directly over the heat.

Sear meat first to trap-in the juices and flavor.

Lower the grill temperature to finish cooking to your preference.

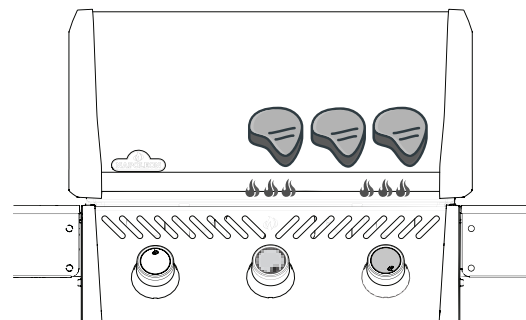

### Indirect Grilling

This method uses lower temperatures and circulates heat around the food cooking it slowly and evenly. Use this method to cook larger cuts of meat, or food prone to flare-ups such as roast, chicken, or turkey.

Turn one or more burners on and place food on the cooking grid where there is no flame, or burner on.

Grilling at a lower temperature and slower cooking time results in more tender meats.

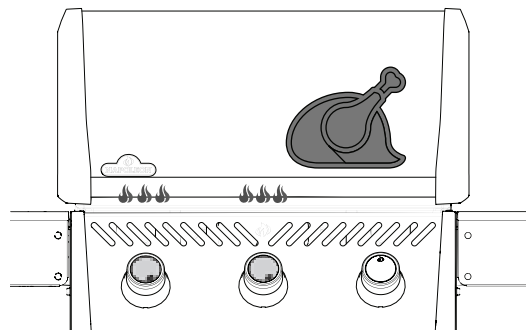

### Infrared Main Burner Use (if equipped)

Follow the “**Main Burner Lighting**” Instructions and operate on high for 5 minutes with the lid closed or until the ceramic burners glow red.

Cook the food directly on the grid(s) following the directions on the “**Infrared Grilling Guide**”. Food can be seared on the infrared burner and then transferred to the main burners of the grill to finish cooking over direct or indirect heat, depending on your taste and preference.

#### GRILLING PRO TIP!

Use a thermometer to check the internal temperature of meat to ensure it is cooked perfectly.

**WARNING!** Never grill food directly on the flame side burner. It is designed for use with pots and pans only.

**WARNING!** Do not close side burner lid while it is operating or hot.

**WARNING!** Do not deep fry food on the side burner. Cooking with oil can be dangerous.



### Flame Side Burner (if equipped)

The flame side burner can be used like a stove top to make gravy or soups.

The maximum pot or pan diameter is 10" (25 cm).

Be sure your grill is in a location protected from the wind, or the performance of the side burner will be affected.

### Infrared Side Burner (if equipped)

To operate, follow the “**Side Burner Lighting**” instructions. The infrared heat provides an even cooking area for searing food when it's set to high.

Some side burner models have a height-adjustable cooking grid.

### Smoker Burner (if equipped)

Place a small amount of wood chips in the solid portion of the smoker tray and follow the “**Main Burner Lighting Instructions**” to ignite the smoker.

Different types of wood (e.g. apple, walnut, hickory) produce different tastes, and they come in multiple variations: chunks, chips, dust or pellets.

A wisp of smoke is enough to get a nice smoky flavor on your food, so be mindful of the quantity of wood used.



**IMPORTANT!** Too much smoke may leave an unpleasant tasting sooty deposit on the food.

### GRILLING PRO TIP!



Get inspired to create delicious meals from the recipes and grilling techniques at [www.napoleon.com](http://www.napoleon.com) and Napoleon's cookbooks.

### Grilling at Night (if applicable)

Illuminate the control knobs by pushing the light bulb icon on the control panel.

When a burner is operating, the corresponding knob will glow red, while the rest will remain blue.

**WARNING!** Regularly clean grease out of the entire unit, including the grease tray and the sear plates, to avoid build-up and grease fires.

**WARNING!** Do not leave food unattended on any lit burners.

**WARNING!** Keep the lid open if main infrared burner is set on high to prevent accidentally burning food.

**WARNING!** Use only untreated wood or wood purchased from an authorized Napoleon dealer.



## HOW TO USE THE REAR BURNER & ROTISSERIE

### Assembling Your Rotisserie Kit (if equipped)

**Note:** Remove the warming rack prior to using the rear burner and spit rod. Extreme heat will damage the warming rack.

1. Install the rotisserie motor on the side of the grill using the mounting bracket(s). Some models have pre-mounted brackets.
2. Once the bracket has been fastened to the grill, slide the rotisserie motor onto the bracket.
3. Slide the first rotisserie fork just past the middle of the spit rod and tighten into place. Thread the meat onto the spit rod and push the meat into the fork. Slide the second rotisserie fork on the opposite end of the spit rod and push the fork into the meat until secure. Tighten the fork into place.

4. Carefully insert the pointed end of the spit rod into the rotisserie motor and set the opposite end across the hangers. The heavy side of the meat will naturally hang down to balance the load.
5. Slide the stop bushing onto the spit rod until it is past the inside of the hood. This will secure the side to side movement of the spit rod.
6. Tighten the stop bushing and spit rod handle. Place a metal dish under the meat to collect the drippings.



**IMPORTANT!** Always wear gloves when handling components of the grill.

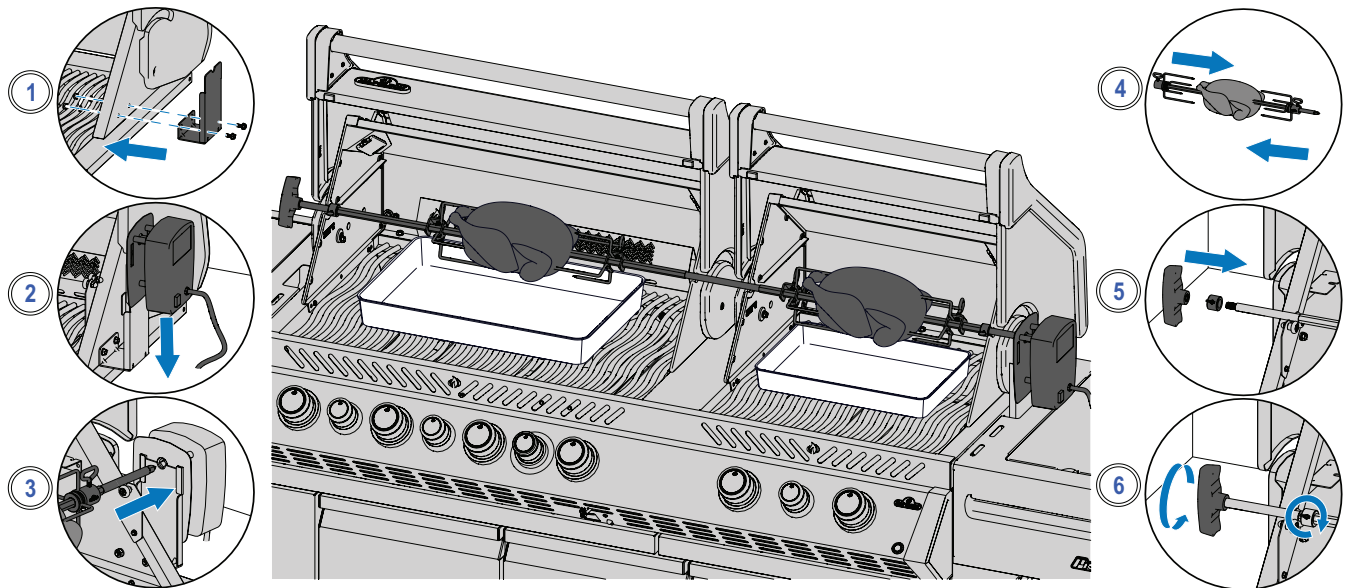

### Tips about using the Rotisserie:

- Operate the rear burner on high until the meat browns. Reduce heat. Keep lid closed.
- Use a thermometer to check the internal temperature of the meat.
- Roasts and poultry should brown on the outside and stay tender on the inside.
- Use drippings to baste and make gravy.
- A 3-pound chicken takes approximately 1 ½ hours on medium to high.
- Be mindful of your rotisserie motor capacity. Never overload your equipment.
- Be sure to always set an evenly balanced load on your rotisserie.

### How to cook multiple chickens

1. Tie or skewer wings to the body of the chickens.
2. Slide rotisserie fork onto spit rod.
3. Thread first chicken onto spit rod until it is held into place by the rotisserie fork. Tighten.
4. Thread next 2 chickens onto spit rod so all the chickens are close together.
5. Slide second rotisserie fork onto spit rod and push into chicken until all 3 chickens are squeezed together tightly. Tighten.

### DID YOU KNOW?

You can remove the cooking grids if they interfere with cooking larger cuts of meat.

**WARNING!** Disassemble rotisserie components when finished cooking, wash with warm soapy water, and store indoors.

**WARNING!** Use heat resistant grilling gloves when handling the hot rotisserie components.

**WARNING!** Disconnect rotisserie plug from the outlet when the grill is not in use.



## ILLUMINATION INSTRUCTIONS

### Motion Sensor and Knobs, Oven and Cabinet Lights (if equipped)



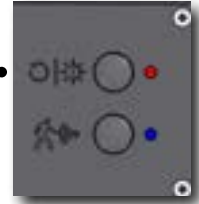

Turn the Power Switch ON located on the box inside the grill cabinet.  
A red and a blue LED light will turn on. Illumination settings are in Default mode.

Brightness: Press the  button to change brightness between high (100%), medium (65%) and low (35%).  
This can only be changed when the knob lights are in White or Blue Mode



### Motion Sensor

- The knob and logo lights will remain ON as long as motion is detected within 1 meter in front of your grill. They will turn off after 15 minutes of inactivity.
- While the motion sensor is ON (as indicated by the blue LED), you can turn the oven and cabinet lights on and off with the  switch.
- Press the  button in the box to turn the sensor OFF (indicated by blue LED).
- Now all your lights are controlled with the  switch.
- The oven and cabinet lights will turn off after two hours.

If the motion sensor is OFF, the knob and logo lights will also shut off after two hours.



### Illumination Modes

#### Default mode

- Knob light mode Blue
- Brightness on high
- Motion Sensor is On

#### Knob lights modes

- Blue
  - White
  - Green - color spectrum mode
- Brightness can be adjusted in these modes only



Select Knob light mode by holding down the  switch to toggle from blue to white to green. Release it on the desired mode.

Go back to Default mode: by holding down the  button for 2 seconds.

### Selecting a Color

- When you have the knobs on the Color spectrum mode the knobs will slowly cycle through the color spectrum, starting at green.
- Quickly Press  Twice to stop the spectrum at any color you choose
- Press twice again to let it continue changing colors.

### Logo light ON / OFF

- The logo and knobs lights work as a set. However, you can also turn the logo light off while keeping the knobs light on.
- **Double click the**  **button to turn on the logo light OFF at any time.**
- **Double click the**  **again to turn back on.**
- If the unit is powered OFF and ON again (main power switch), the logo light will return to its default mode



## THE GRILLING EXPERIENCE CHECKLIST

Refer to this list every time you grill

**Read Owner's Manual**

Be sure to have read the owner's manual and all the safety instructions.

**Clean grease tray**

Always ensure you clean the grease tray prior to grilling to avoid fires and flare-ups.

**Check the hose**

Ensure the grill is off and cool. Check the hose for evidence of excessive abrasions, or cuts. Have the hose replaced before use if the hose is damaged.

**Preheat and clean grids**

Coat the grids with vegetable shortening and preheat your grill to burn off excess residue and prevent sticking. Clean cast iron grids with a brass wire brush and stainless steel grids with a stainless brush. See "**Cleaning Instructions**".

**NOTE:** Stainless steel cooking grids are corrosion resistant and require less maintenance than cast iron grids.

**Prep area**

Make sure everything you need while grilling such as your utensils, seasonings, sauces, and dishes are within your reach. Don't leave your food unattended, or it could burn.

**Flip once and do not peek**

Try not to open the lid and peek too much, or heat will escape and throw your temperature and cooking times off. Flip your food only once, especially steak and chicken.

**Leave space**

Leave some space on the grill and between food, so you have room to move food around if you need to.

**Use a thermometer**

Use a thermometer to ensure food is cooked thoroughly. Follow the appropriate temperatures guidelines for all types of meat, especially poultry.

**BE CAREFUL!**



The lid of the grill and the entire firebox can become very hot when in use.

**GRILLING PRO TIP!**



Always preheat the grill before cooking to burn off leftover residue and prevent food from sticking to the grate.

**OIL AND FAT SUGGESTION!**



- Grapeseed Oil
- Sunflower Oil
- Soybean Oil
- Extra Virgin Olive Oil
- Canola Oil

If not available, select an oil or fat that has a high smoke point. Do not use salted fats like butter or margarine.

### HOW TO SEASON CAST IRON COOKING GRIDS (IF APPLICABLE)







This procedure **MUST** be done prior to first use and repeated every 3-4 uses to keep grids looking new.

1. Remove cast iron grids from the grill.
2. Wash grids with warm soapy water and soft cloth. Pat dry and allow grids to completely dry.
3. Apply fat/oil evenly using a silicone brush on both sides.
4. Preheat appliance to 350°F - 400°F (176°C - 204°C).
5. Install cooking grids and cook for 30 minutes.
6. Apply a second even coat of fat/oil on cooking grids, and keep cooking for 30 more minutes.
7. Grids are now seasoned.

**NOTE:** If rust has formed on the cast iron grids, remove the rust with scouring pad or brass brush and repeat the seasoning process.



# Infrared Grilling Guide

FOOD	CONTROL KNOB SETTING	COOKING TIME	SUGGESTIONS
 <b>Steak</b> 1 inch (2.54 cm) thick	HIGH – 2 minutes each side	Rare – 4 minutes	Ask for marbled fat in cut. Fat is a natural tenderizer and keeps meat juicy.
	HIGH to MEDIUM – High heat 2 minutes each side then turn to medium heat	Medium – 6 minutes	
		Well done – 8 minutes	
 <b>Hamburger</b> ½ inch (1.27 cm) thick	HIGH – 2 minutes each side	Rare – 4 minutes	Keep patties all the same thickness for equal cooking times. Patties 1 inch thick or more should be grilled using indirect heat.
	HIGH – 2 ½ minutes each side	Medium – 5 minutes	
	HIGH – 3 minutes each side	Well done – 6 minutes	
 <b>Chicken</b>	HIGH, MEDIUM, LOW – 2 minutes each side then medium-low to low heat	20 – 25 minutes	Slice joint connecting the thigh and leg ¾ through for the meat to lie flat on the burner and cook evenly.
 <b>Pork Chops</b>	MEDIUM	6 minutes each side	Choose thick cuts for more tender meat. Trim off excess fat.
 <b>Spare Ribs</b>	HIGH to LOW – High for 5 minutes then low until finished	20 minutes each side turning often	Choose lean meaty ribs. Grill until meat pulls easily from the bone.
 <b>Lamb Chops</b>	HIGH to MEDIUM – High for 5 minutes then Medium until finished	15 minutes each side	Choose thick cuts for more tender meat. Trim off excess fat
 <b>Hot dogs</b>	MEDIUM to LOW	4 – 6 minutes	Select larger wieners and slit lengthwise before grilling

# Cleaning Instructions

## First Time Use

1. Wash grids by hand with water and mild dish soap to remove any residue from the manufacturing process. **DO NOT** wash in a dishwasher.
2. Rinse thoroughly with hot water and dry completely with a soft cloth to prevent moisture from entering the cast iron.

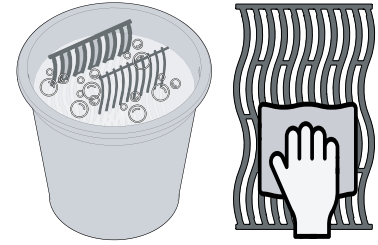

## Cast Iron Grids

- Season your grids to add a protective coating to prevent corrosion. See Grilling Tips – **How to Season your Cast Iron Cooking Grids.**

## Stainless Steel Grids

- Stainless steel cooking grids can be cleaned by preheating the grill and using a wire brush to remove residue.
- Stainless steel grids will permanently discolor from regular use because of high temperatures when grilling.

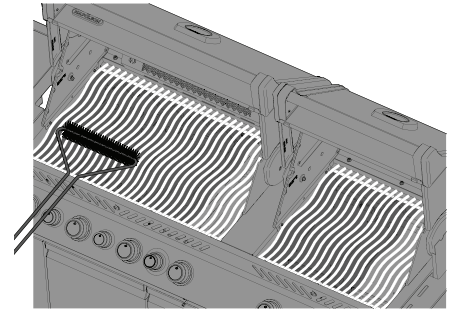

## Infrared Side Burner

- Most drippings and food particles that fall on the infrared burner surface incinerates immediately because of the high intensity heat.
- Do not clean the ceramic tile with a wire brush.
- Do not use water or other liquids to clean the burner. An immediate change in temperature will cause cracking of the ceramic tile.
- Light burner and operate on high for 5-10 minutes to remove any left-over residue.

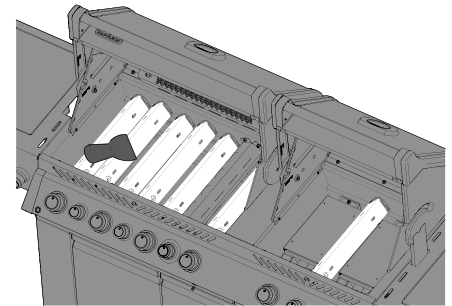

## Inside of the Grill

1. Remove the cooking grids.
2. Use a brass wire brush to clean loose debris from the sides and underneath the lid.
3. Scrape the sear plates with a putty knife or scraper. Use a wire brush to remove the ash.
4. Remove the sear plates and brush debris from the burners with a wire brush.
5. Sweep debris from inside the grill into the drip pan.

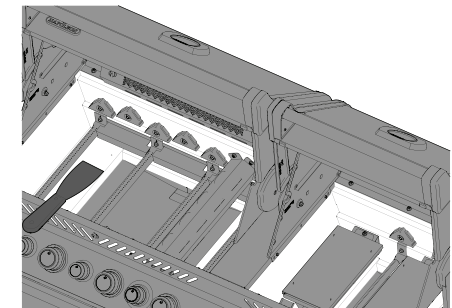
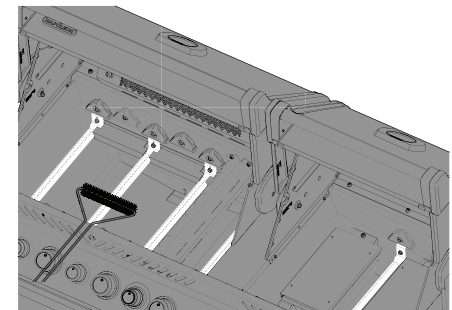

**WARNING!** Always wear protective gloves and safety glasses when cleaning your grill.

**WARNING!** Accumulated grease is a fire hazard.

**WARNING!** Cleaning should only be done when the grill is cool to avoid the possibility of burns.



## Drip Pan

Every grill head, side burner and drop-in burner have a corresponding drip pan. It is easily accessible through doors or openings.

- Grease and excess drippings collect in the drip pan located beneath the grill and accumulate in the disposable grease tray below the drip pan (if applicable).
- Only use Napoleon approved liners on the drip pan. Never use aluminum foil, sand or any other unapproved material. This can prevent grease from flowing properly.
- Clean frequently to avoid grease build-up – approximately every 4-5 uses.

Cleaning steps:

1. Slide the drip pan from the grill to access the disposable grease tray or to clean the drip pan.
2. Scrape the drip pan out with a putty knife or scraper.
3. Replace the disposable grease tray every 2-4 weeks depending on grill usage (if applicable).
4. See your Napoleon Grill dealer for supplies.

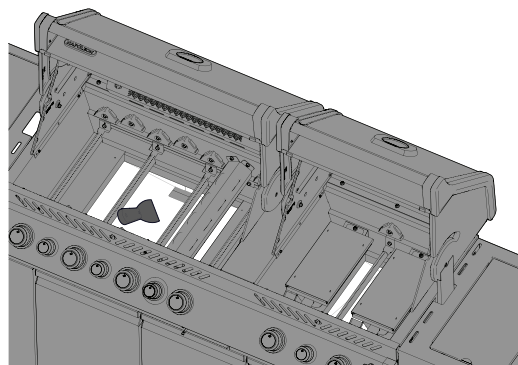

## Control Panel

ONLY use warm soapy water.

Text is printed directly on the control panel and will gradually rub off if abrasive or stainless steel cleaners are used.

Proper cleaning of the control panel will ensure the text remains dark and legible.

## Aluminum Castings

Clean with warm soapy water.

Aluminum doesn't rust, but high temperatures and weathering can cause oxidization on the surface of the castings that look like white spots.

See "**Maintenance Instructions**" for more information on how to prevent oxidized aluminum.

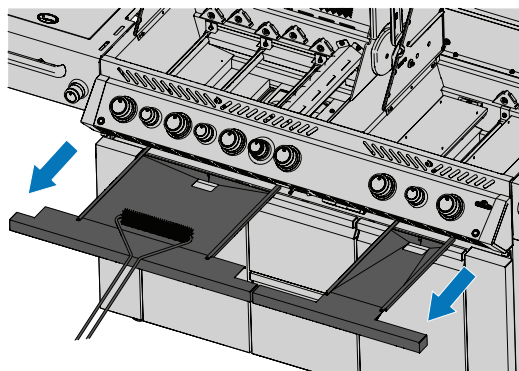

## Outside Grill Surface

- Only use a non-abrasive cleaner. Abrasive cleaners or steel wool will scratch the finish.
- Always wipe in the direction of the grain.
- Handle porcelain enamel components with care.
- The baked-on enamel finish is glass-like and will chip if struck.
- Stainless steel parts discolor overtime when heated and will turn a golden or brown hue. This is normal and won't affect the performance of the grill.

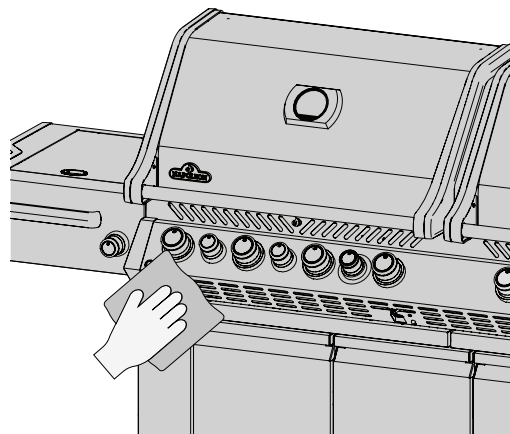

**WARNING!** Ensure all burners are turned off and grill is cool before cleaning. Do not use oven cleaner to clean any part of the grill. Do not put cooking grids or any other parts of the grill in a self-cleaning oven to clean. Clean the grill in an area where cleaning solution won't harm decks, lawns, or patios.

**WARNING!** Barbecue sauce and salt can be corrosive and will cause rapid deterioration of the grill components unless cleaned regularly.



### Insect Screen and Burner Ports

Spiders and insects are attracted to small enclosed spaces.

Napoleon has equipped the burner with an insect screen on the air shutter. This reduces the likelihood of insects building nests inside the burner, but doesn't eliminate the problem.

A nest or web can cause the burner flame to burn a soft yellow or orange and cause a fire or flashback at the air shutter underneath the control panel.

1. Remove the screw (s) that attaches the burner to the back wall of the grill. Slide the burner back and upwards to remove.
2. Use a flexible venturi tube brush to clean the inside of the burner.
3. Shake loose debris from the burner through the gas inlet.
4. Check the burner ports and valve orifices for blockages: burner ports can close over time because of cooking debris and corrosion.
5. Use an opened paper clip, or the supplied port maintenance bit to clean burner ports.
6. Drill out blocked ports using the supplied drill bit in a small cordless drill: this can be done with the burner attached to the grill, but it's easier if removed from the grill.
7. Do not flex the drill bit when drilling the ports because the drill bit will break.
8. This drill bit is for burner ports NOT for brass orifices that regulate the gas flow to the burner.
9. Do not enlarge the holes
10. Ensure the insect screen is clean, tight, and free of any lint or other debris.
11. Reverse the procedure to reinstall the burner.
12. Ensure the valve enters the burner when installing.
13. Replace sear plate mount and tighten screws to complete re-installation.

#### SAFETY FIRST!



Always wear protective gloves and safety glasses when servicing your grill.

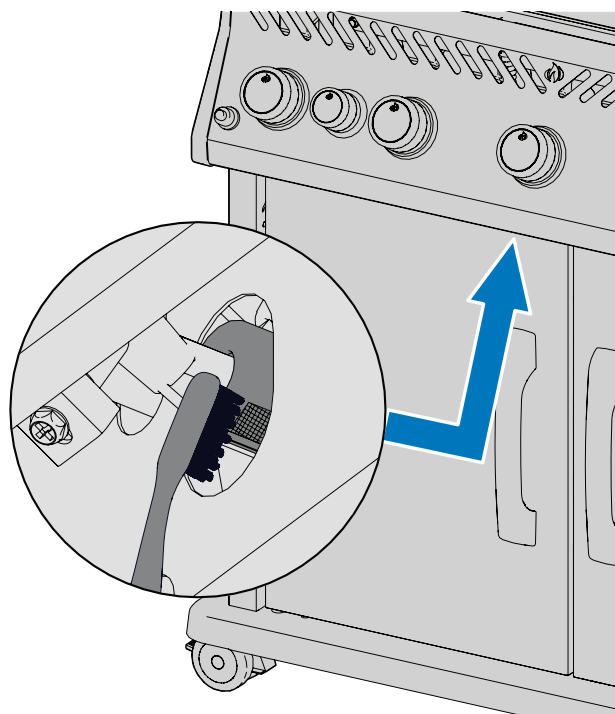

Illustration only applies to PRESTIGE PRO 500.

**WARNING!** It is very important the valve/orifice enters the burner tube when reinstalling the burner after cleaning and before lighting your grill, or a fire or explosion could occur.

**WARNING!** Avoid unprotected contact with hot surfaces.

**WARNING!** Do not use abrasive cleaners or steel wool on any painted, porcelain, or stainless steel parts of your grill because it will scratch the finish.



# Maintenance Instructions

## RECOMMENDATIONS

This grill should be thoroughly inspected and serviced annually by a qualified service person.

- Do not obstruct the flow of ventilation and combustion air.
- Keep the cylinder enclosure ventilation openings located on the side of the cart or enclosure and front and back of the bottom shelf clear from debris.

**WARNING!** Keep the grill away from combustible materials, gasoline, and other flammable vapors and liquids.



## COMBUSTION IN AIR ADJUSTMENT

**!** **IMPORTANT!** This must be done by a qualified gas installer.

- The air shutter is factory set and should not require adjusting under normal conditions. Adjustments might be required under extreme field conditions.
- The flames of the air shutter will be dark blue, tipped with light blue and occasionally yellow when adjusted correctly.
- Too little air flow to the burner will produce soot and lazy yellow flames.
- Too much air flow to the burner will cause flames to lift erratically and cause igniting difficulties.

**Note:** Infrared burners have no air adjustment.

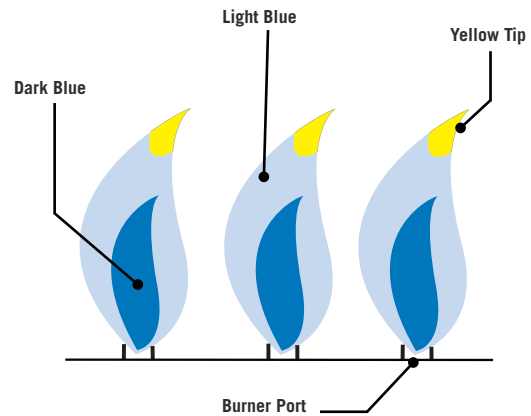

**WE WANT  
TO HELP!**



Contact the Napoleon  
Customer Solutions  
Department for  
recommended  
replacement parts.  
+31 345 588655.

## STAINLESS IN HARSH ENVIRONMENTS

Stainless steel oxidizes or stains in the presence of chlorides and sulfides, especially in coastal regions, warm and highly humid areas, and around pools and hot tubs. These stains look like rust, but they can be easily removed or prevented. Wash stainless and chrome surfaces every 3-4 weeks. Clean with warm soapy water.

### Burner Maintenance

- Extreme heat and a corrosive environment can cause surface corrosion to occur even though the burner is made from heavy wall 304 stainless steel.

### Maintenance and Protection of Infrared Burners

Your infrared burners are designed to provide a long service life, but you must be careful to prevent cracking of their ceramic surfaces. Fractures will cause the burners to malfunction.



**IMPORTANT!** Damage resulting from by failure to follow these instructions is NOT covered by your grill warranty.

### Replacing Oven Halogen Bulbs (if equipped)

- Remove the screw securing the housing in place.
- Snap the lens and metal bracket out of the housing.
- Wearing protective gloves, gently pull the old bulb from the socket and replace with the new bulb.
- Reinstall the lens into the housing and bend the tabs on the front back into position.

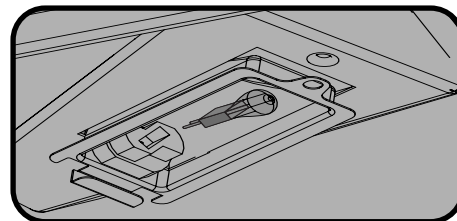
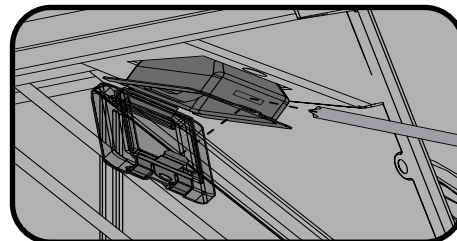
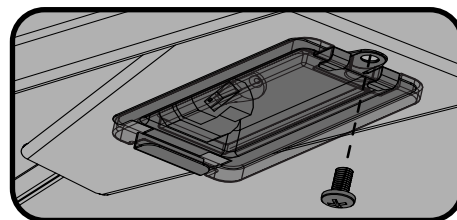

**WARNING!** Turn off gas at the source and disconnect the unit before servicing.

**WARNING!** Maintenance should only be done when the grill is cool to avoid the possibility of burns.

**WARNING!** A leak test must be performed annually and when any component of the gas train is replaced, or when the smell of gas is present.



### Steps to Avoid Damaging Ceramic Surfaces

1. Never douse a flame or control flare-ups with water.
2. Do not allow cold water (rain, sprinkler, hose etc.) to come in contact with hot ceramic burners. An immediate change in temperature will cause cracking of the ceramic tile.
3. A ceramic burner that becomes wet before use will create steam when operated later and produce pressure that will crack the ceramic.
4. Repeated soaking of the ceramic can cause it to swell and expand producing pressure that will make the ceramic crack and crumble.
5. Inspect the ceramic for possible water soaking if you find standing water in the grill. Remove the burner if the ceramic is wet. Turn it upside down to drain the excess water. Bring ceramic indoors to dry thoroughly.
6. Do not allow hard objects to impact the burner. Take care when inserting or removing cooking grids and using accessories.

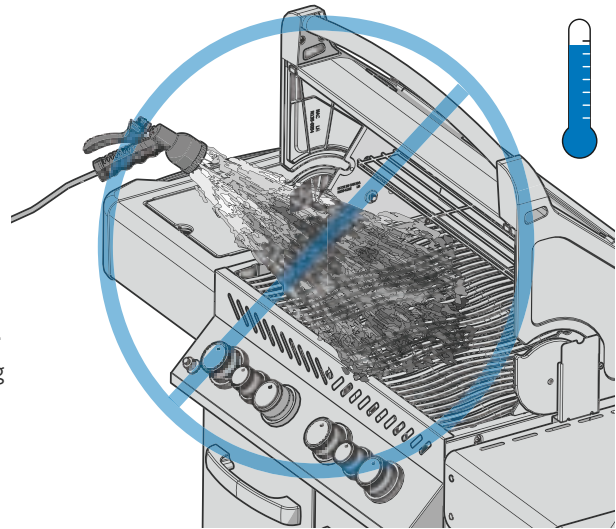

### Clearance Ventilation of hot air

- Hot air must have a way to escape the grill for the burners to function properly.
- The burners can become deprived of oxygen if the hot air is not allowed to escape causing them to back-flash. The ceramic can crack if this occurs repeatedly.

#### SAFETY FIRST!



Never cover more than 75% of any main or side burner cooking surface with cookware (e.g. griddles, baking sheets, or pans).

# Troubleshooting

## Lighting Problems

- Main, rear or side burners will not light with the igniter, but will light with a match.
- Burners will not cross light each other.

	Possible causes	Solution
Main Burner	JETFIRE™ outlet is dirty or clogged	Clean JETFIRE™ outlet with a soft bristle brush.
	Dirty or corroded cross light brackets.	Clean or replace as required.
Rear and Side Burners	Dead battery, or installed incorrectly.	Replace with premium heavy-duty battery.
	Loose electrode wire or switch terminal wires.	Check electrode wire is firmly pushed onto the terminal on the back of the igniter. Check the lead wires from the module to the ignition switch (if equipped) are firmly pushed onto their respective terminals.
	Lifting flames on burner.	Close air shutter according to " <b>Maintenance Instructions</b> "- <b>Combustion Air Adjustment</b> section in this Owner's Manual. <b>IMPORTANT!</b> This must be done by a qualified gas installer.

## Noises and Flare-ups

- Humming regulator.
- Excessive flare-ups and uneven heat.

Possible causes	Solution
Normal humming noise on hot days.	This isn't a defect. It's caused by internal vibrations in the regulator and doesn't affect the performance or safety of the grill. Humming regulators WILL NOT be replaced.
The cylinder valve was opened too quickly.	Open cylinder valve slowly
Sear plates installed incorrectly.	Ensure sear plates are installed with holes towards the front, and the slots on the bottom. See Assembly Instructions Guide.
Improper heating.	Preheat grill with all main burners on high for 10 to 15 minutes.
Excessive grease and ash build on sear plates and in drip pan.	Clean sear plates and drip pan regularly. Do not line pan with aluminum foil. Refer to " <b>Cleaning Instructions</b> ".

### Illumination Problems

- Oven Halogen Bulbs not working.
- Control Panel lights not working.

Possible causes	Solution
Unit is not connected to power	Plug power cord (from working GFI protected outlet) into electrical box on the back of the grill. Plug transformer cord into power box.
Blown fuse	Replace fuse located on outlet line of transformer.
Faulty transformer	Check transformer output – should be 12VAC. Replace if required.
Terminal on switch or circuit board are corroded or loose	Clean connections and ensure connectors are pushed together firmly. Access to circuit board is under electrical cover on left side of cabinet.
Halogen bulbs blown (oven lights only)	Replace bulbs as per the instructions in the “ <b>Maintenance Instructions</b> ”- <b>Replacing Oven Halogen Bulbs</b> section of this Owner’s Manual

**Gas Flow**

- Low heat or low flame when valve is turned to high.
- Burners burn with yellow flame, accompanied by the smell of gas.
- Flames lift away from burner, accompanied by the smell of gas, and possible lighting difficulties.
- Burner output on HIGH, but setting is LOW. Rumbling noise and fluttering blue flame at burner surface.

Possible causes	Solution
Propane – improper lighting procedure	Ensure lighting procedure is followed carefully. All gas valves must be in the OFF position when the tank valve is turned on. Turn tank on slowly to allow pressure to equalize. See Operation – <b>"Lighting Instructions"</b> .
Natural gas – undersized supply line.	Pipe must be sized according to installation code.
Leaking gasket surrounding the ceramic tile, or a weld failure in the burner housing.	Allow burner to cool and inspect very closely for cracks. Contact your authorized Napoleon dealer to order replacement burner assembly if any cracks are found.
Both gas propane and natural gas – improper preheating.	Preheat grill with both main burners on high for 10 to 15 minutes.
Possible spider web or other debris.	Thoroughly clean nest or webs out of your burner orifice by removing it and following instructions in this manual. See <b>"Leak Test"</b> .
Improper air shutter adjustment.	Open or close air shutter slightly according to this manual. See <b>"Maintenance Instructions"</b> . <b>IMPORTANT!</b> This must be done by a qualified gas installer.
Lack of gas	Check gas level in propane cylinder.
Supply hose is pinched.	Reposition supply hose as necessary.
Propane regulator in low flow state.	Turn the burners off and close the tank valve, wait 5 minutes before fully re-opening the valve, allow a few seconds for the pressure to equalize before following the Lighting Instructions to start the grill. Ensure igniting procedure is followed carefully every time you cook. All gas valves must be OFF when the tank valve is turned on. Always open the tank valve slowly.



**WE WANT TO HELP!**

---

Napoleon is here to ensure your grilling experience is memorable. Contact us if you require additional help.

### Infrared Burner Flashes Back

- During operation the burner abruptly makes a loud whoosh sound, followed by a continuous blow-torch type sound and grows dim or has a large flame on start up.

Possible causes	Solution
Ceramic tiles overloaded with grease drippings and build-up. Ports are clogged	Turner burner OFF and allow to cool for at least 2 minutes. Reignite burner and burn on HIGH for at least 5 minutes, or until the ceramic tiles are evenly glowing red.
Burner overheated because inadequate ventilation. Too much grill surface covered by griddle or pan.	Ensure no more than 75% of the grill surface is covered by objects or accessories. Turn burner OFF and allow to cool for at least 2 minutes. Reignite.
Leaking gasket surrounding the ceramic tile, or a weld failure in the burner housing.	Allow burner to cool and inspect very closely for cracks. Contact your authorized Napoleon dealer to order replacement burner assembly if any cracks are found.
Improper heating.	Preheat grill with both main burners on high for 10 to 15 minutes.
Excessive grease and ash build on sear plates and in drip pan.	Clean sear plates and drip pan regularly. Do not line pan with aluminum foil. Refer to " <b>Cleaning Instructions</b> ".

### Peeling Paint

- Paint appears to be peeling inside lid or hood.

Possible causes	Solution
Grease build-up on inside surfaces.	This is not a defect. The finish on the lid and hood is porcelain or stainless steel and will not peel. The peeling is caused by hardened grease, which dries into paint-like shards, that flake off. Regular cleaning will prevent this. See " <b>Cleaning instructions</b> ".

## DIAGRAM FOR ELECTRICAL CONNECTIONS: PR0825

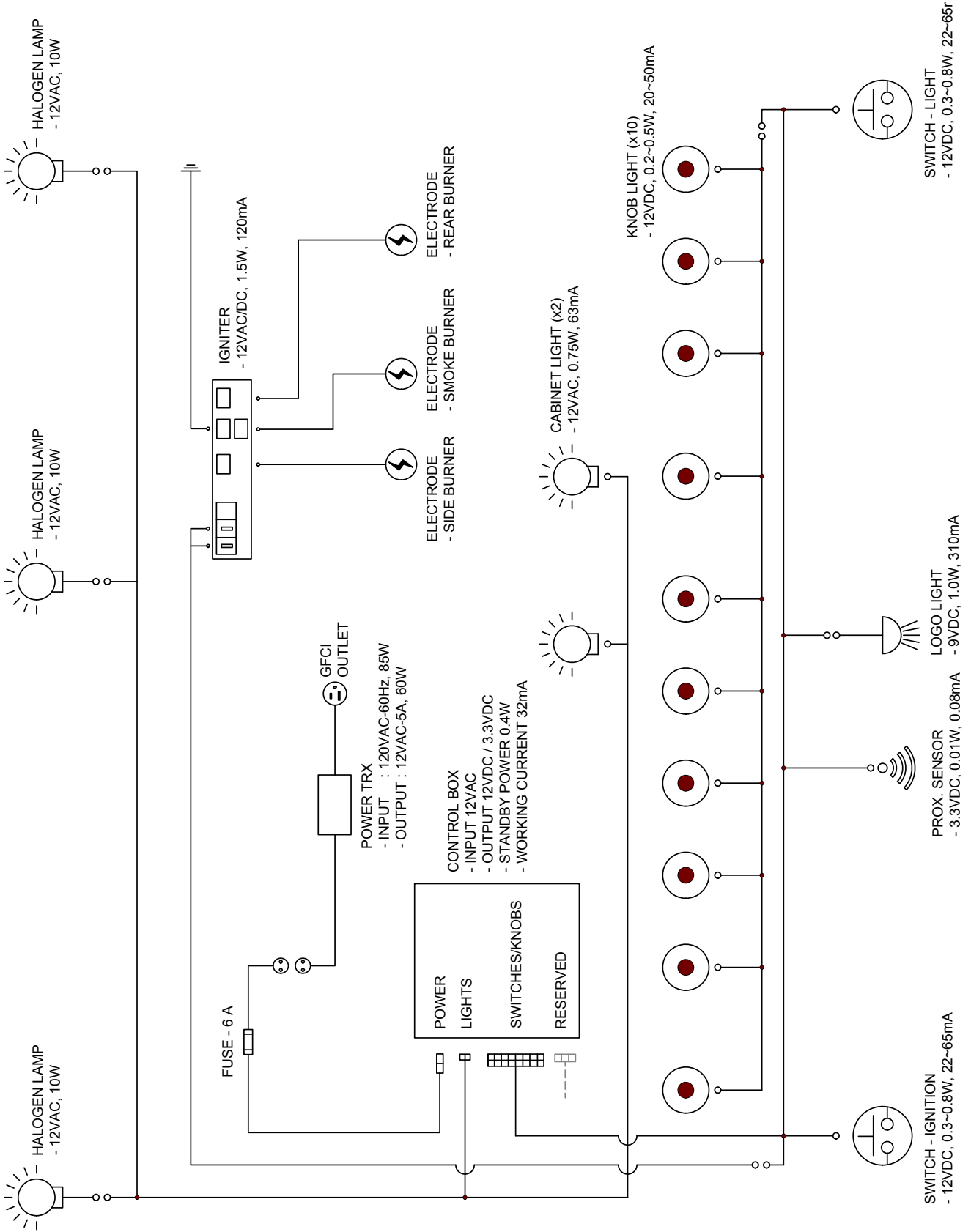

# DIAGRAM FOR ELECTRICAL CONNECTIONS: PR0665

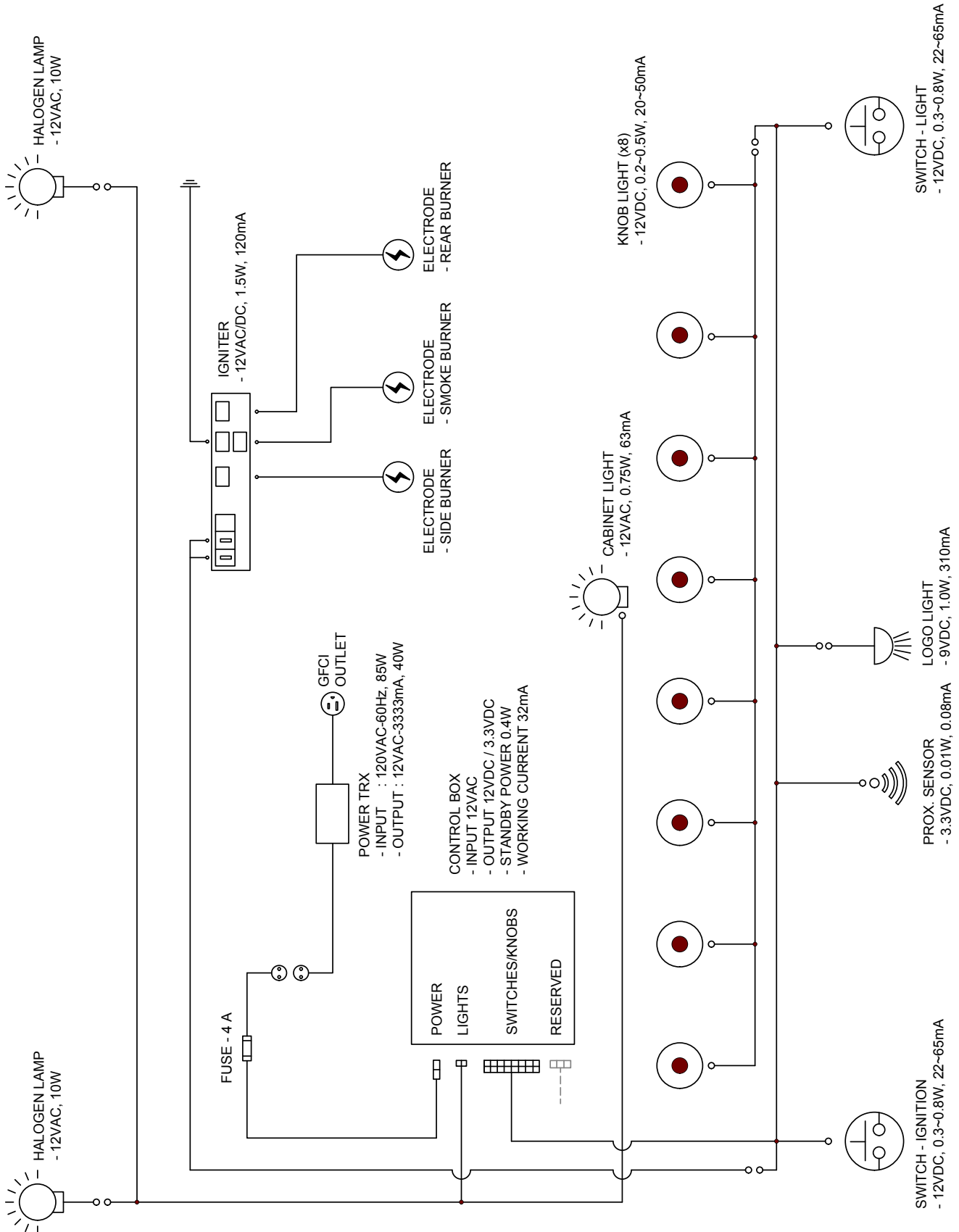
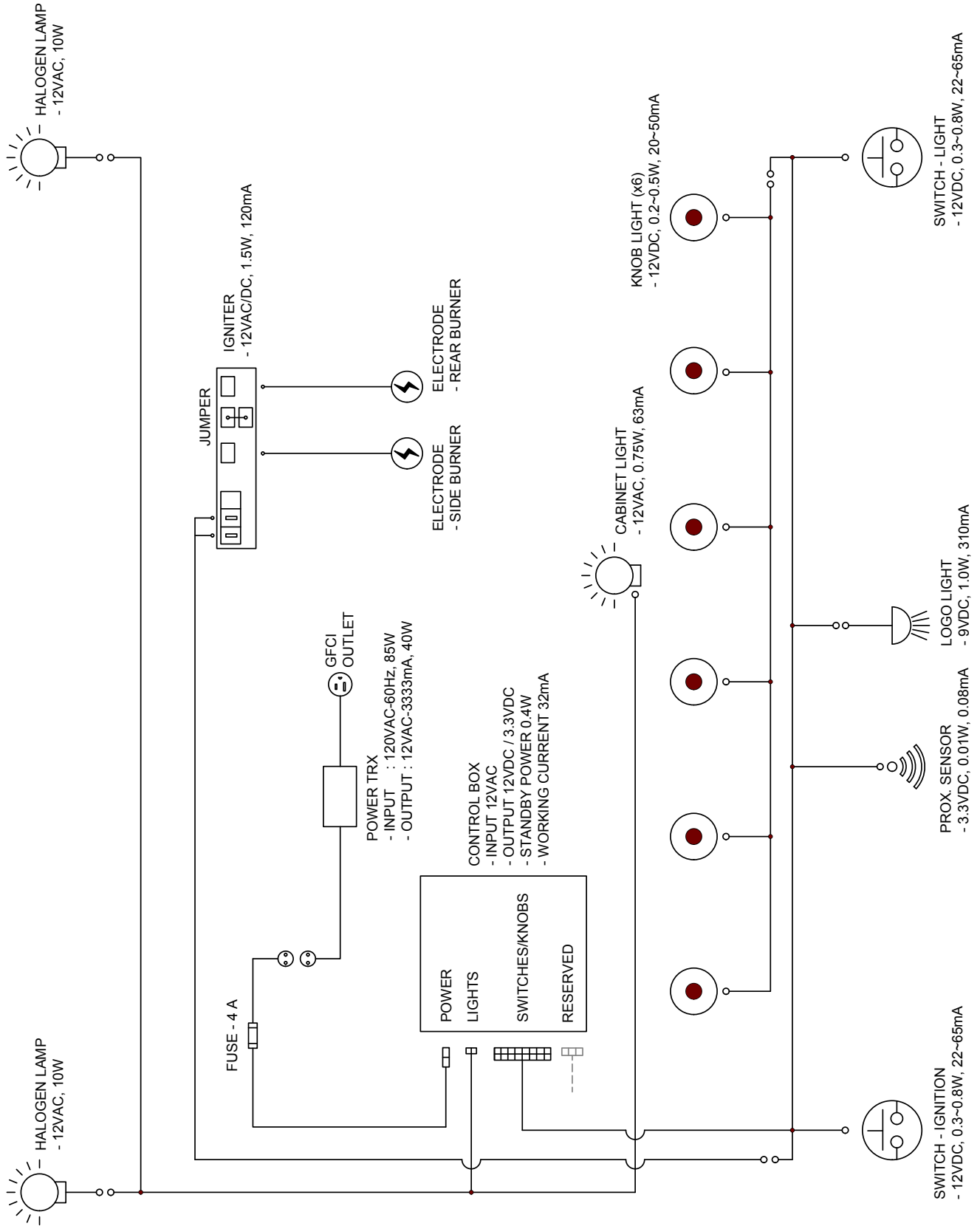

DIAGRAM FOR ELECTRICAL CONNECTIONS: PR0500





# NAPOLEON PRODUCT WARRANTY

The present warranty details apply to products purchased after January 1, 2022.

**Refer to your Napoleon Grills Owner's Manual for detailed information on your warranty.**



## FOR PRESTIGE®/PRO™ GRILL CARTS AND BUILT-IN HEADS President's Limited Lifetime Warranty on Napoleon Gas Grills

NAPOLEON warrants that the components of your new NAPOLEON product will be free from defects in materials and workmanship from the date of purchase for a period of:

Aluminum Castings / Stainless Steel Frame.....	Lifetime*
Stainless Steel Lid.....	Lifetime*
Porcelain-Enameled Lid.....	Lifetime*
Stainless Steel Cooking Grids.....	Lifetime*
Stainless Steel Side Table.....	Lifetime*
Stainless Steel Tube Burner.....	10 Years <sup>plus Id</sup>
Porcelain-Coated Cast Iron Cooking Grids.....	10 Years <sup>plus Id</sup>
Stainless Steel Flame Arrester Inserts.....	5 Years <sup>plus Id</sup>
Stainless Steel Infrared Burner for Rotisserie.....	5 Years <sup>plus Id</sup>
Bottom Ceramic Infrared Burner or Ceramic Infrared Side Burner (excluding screen).....	5 Years <sup>plus Id</sup>
Ceramic Infrared Burner for Rotisserie (excluding mesh).....	5 Years <sup>plus Id</sup>
All Other Parts.....	2 Years

**Plus Id:** refers to an extended warranty period, during which we supply spare parts to the purchaser at 50% of the current retail price for the lifetime\* of the grill.

**Plus 15:** refers to an extended warranty period, during which we supply spare parts to the purchaser at 50% of the current retail price for an additional 15 years.

**Plus 10:** refers to an extended warranty period, during which we supply spare part to the purchaser at 50% of the current retail price for an additional 10 years.

**\*Lifetime:** refers to a warranty period of 30 years.

**This warranty is valid in:** the European Union, Switzerland, Andorra, San Marino, Norway, Iceland and Liechtenstein.

The customer's legal entitlements in the event of defects in accordance with WKRL - (EU) 2019/711) are not affected, restricted or altered by the present warranty. The exercise of statutory entitlements is to take place free of charge.

### WARRANTY CONDITIONS AND LIMITATIONS

NAPOLEON guarantees that its products are free from defects exclusively to the original purchaser, and only insofar as the purchase took place through an official NAPOLEON dealer. The following conditions and restrictions apply:

The present manufacturer's warranty is not transferable nor viable for extension under any circumstances or by any of our representatives.

The gas grill must be installed by a licensed, authorized service technician or contractor. Installation must take place in accordance with the installation instructions provided, as well as all local and national building and fire codes.

This limited warranty does not cover damage caused by improper operation, lack of maintenance, grease fire, environmental exposure, accidents, modification, abuse, or neglect. The installation of spare parts from other manufacturers voids the present warranty. The discoloration of plastic elements due to the application of chemical cleaning agents or exposure to sunlight is not covered under this warranty.

This warranty also excludes any of the following: Scratches, dents, paint defects, coatings, corrosion or discoloration caused by exposure to heat or abrasive and chemical cleaners, as well as chips to porcelain-coated parts and any components used in the installation of the gas grill.

If a part deteriorates to the point where it becomes inoperable (due to rusting or burning through) within the warranty period, the customer will be issued with a replacement part.

After the first year, NAPOLEON has the authority under this warranty (President's Limited Lifetime Warranty, 15 Year Limited Warranty, 10 Year Limited Warranty, 3 Year Limited Warranty) to waive any warranty obligation at its free discretion by refunding the original purchaser to the tune of the wholesale price of the relevant defective warranty parts.

NAPOLEON accepts no responsibility for any installation, labor hours or other costs or expenses associated with the reinstallation of a warranty part. Costs of this nature are not covered by the present warranty.

Notwithstanding any regulations under this warranty (President's Limited Lifetime Warranty, 15 Year Limited Warranty, 10 Year Limited Warranty, 3 Year Limited Warranty), NAPOLEON's liability under this warranty is defined by the foregoing, and does not cover any incidental, consequential, or indirect damage in any case whatsoever.

This warranty defines NAPOLEON's duties and liability with respect to the NAPOLEON gas grill. NAPOLEON assumes no further liability in connection with the sale of this product, nor does it authorize any third party to assume any other liability on its behalf.

NAPOLEON assumes no responsibility for: Overheating, extinguishing of the flame by environmental factors such as strong winds or inadequate ventilation.

NAPOLEON does not accept liability for any damage to the gas grill caused by the weather, hail, rough handling, aggressive chemicals or cleaning agents.

Warranty claims must be accompanied by the proof of purchase or a copy thereof stating the serial and model number.

NAPOLEON reserves the right to have the product or any part thereof inspected by one of its representatives prior to the fulfilment of any warranty obligation.

NAPOLEON does not bear shipping costs, labor hours or export duties.

#### **GUARANTOR:**

NAPOLEON EUROPE | WOLF STEEL EUROPE B.V.  
De Riemsdijk 22 | 4004LC | Tiel | Gelderland Netherlands

**Phone:** +31 345 588 655

**Fax:** +31 345 588 655

**E-mail:** de.info@napoleon.com

# NAPOLEON - CELEBRATING OVER 40 YEARS OF HOME COMFORT PRODUCTS



Napoleon products are protected  
by one or more U.S. and Canadian  
and/or foreign patents or patents  
pending.

De Riemsdijk 22, 4004 LC, Tiel, The Netherlands  
10-12 Home Farm, Meriden Road, Berkswell, CV7 7SL, United Kingdom  
24 Napoleon Road, Barrie, Ontario, L4M 0G8, Canada

PHONE: +31 345 588655  
[www.napoleon.com](http://www.napoleon.com)  
[eu.info@napoleon.com](mailto:eu.info@napoleon.com)

Last Revision | C-0 | 06.21.24

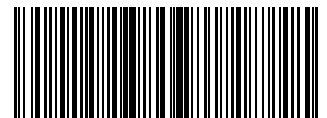

N415-0652CE-GB

[Napoleon.com](http://Napoleon.com) | Prestige Pro<sup>®</sup> Series