

RMB60HPNGFSS/ Gas Hob

User Guide

&

Installation & Service Instructions

RANGEmaster

U110601 - 05

Contents

1. Before You Start...	1	5. Installation	8
Installation and Maintenance	1	Dear Installer	8
Peculiar Smells	1	Provision of Ventilation	9
If You Smell Gas	1	Conversion	9
Ventilation	1	Positioning the Hob	10
Personal Safety	1	6. Conversion to LPG	13
Cleaning	2	Injectors	13
2. Hob Overview	3	Tap Adjustment	14
Wok Ring Burner	4	Affix Label	14
Hob Care	4	Pressure Testing	14
3. Cleaning Your Hob	5	Lubrication of the Gas Taps	14
Essential Information	5	Conversion to LP	15
Hotplate Burners	5	Gas Connection	15
Cleaning Table	6	Connection to the Gas Supply	16
4. Troubleshooting	7	Pressure Testing	17
		Electrical Connections	18
		Hotplate checks	18
		Customer Care	18
		7. Circuit Diagram	19
		8. Technical Data	20
		9. Warranty/After Sales Service	22

1. Before You Start...

Thank you for buying a Rangemaster hob. It should give you many years trouble-free cooking if installed and operated correctly. It is important that you read this section before you start, particularly if you have not used a gas hob before.

⚠ CAUTION: This appliance is for cooking purposes only. It must not be used for other purposes, for example room heating. Using it for any other purpose could invalidate any warranty or liability claim. Besides invalidating claims this wastes fuel.

Installation and Maintenance

In the UK, the hob must be installed by a CORGI registered gas engineer. The electrical installation should be in accordance with BS 7671. Otherwise, all installations must be in accordance with the relevant instructions in this booklet, with the relevant national and local regulations, and with the local gas and electricity supply company requirements.

Make sure that the gas supply is turned on and that the hob is wired in and switched on (the hob needs an electricity supply for ignition).

It is recommended that this appliance is serviced annually.

Only a qualified service engineer should service the hob and only approved spare parts should be used.

Always allow the hob to cool and then switch it off at the mains before cleaning or carrying out any maintenance work, unless specified otherwise in this guide.

Peculiar Smells

Make sure the room is well ventilated to the outside air (see 'Ventilation' below). People with respiratory problems should vacate the area for this brief period.

If You Smell Gas

- **DO NOT** turn electric switches on or off
- **DO NOT** smoke
- **DO NOT** use naked flames
- Do turn off the gas at the meter or cylinder
- Do open doors and windows to get rid of the gas
- Do keep people away from the area affected
- Call your gas supplier

If you are using natural gas in the UK ring the National Grid on: 0800 111 999.

Ventilation

CAUTION: Using a gas cooking appliance will result in the production of heat and moisture in the room in which it is installed. Make that the kitchen is well ventilated; keep natural ventilation holes open or install a powered cooker hood that vents outside. If you have several burners on or use the hob for a long time, open a window or turn on an extractor fan.

Personal Safety

- ⚠ Accessible parts will become hot during use and will retain heat even after you have stopped cooking. Keep babies and children away from the hob and never wear loose-fitting or hanging clothes while the appliance is in use.**
- ⚠ When the hob is not in use make sure that the control knobs are in the OFF position.**
- ⚠ DO NOT use hotplate protectors, foil or hotplate covers of any description. These may affect the safe use of your hotplate burners and are potentially hazardous to health.**
- ⚠ Always keep combustible materials, e.g. curtains, and flammable liquids a safe distance away from your hob.**
- ⚠ Do not spray aerosols in the vicinity of the hob while it is on.**
- ⚠ Use dry oven gloves when applicable – using damp gloves might result in steam burns when you touch a hot surface. Do not use a towel or other bulky cloth in place of a glove – it might catch fire if brought into contact with a hot surface.**
- ⚠ Never operate the hob with wet hands.**
- ⚠ Never heat unopened food containers. Pressure build up may make the containers burst and cause injury.**
- ⚠ Do not use unstable saucepans. Always ensure that you position the handles away from the edge of the hotplate.**
- ⚠ Take care NOT to place metallic objects such as knives, forks, spoons and lids on the hob surface since they can get hot.**
- ⚠ The appliance is not intended to be operated by means of external timer or separated remote-control system.**

Never leave the hotplate unattended at high heat settings. Pans boiling over can cause smoking, and greasy spills may catch on fire. Use a deep fat thermometer whenever possible to prevent fat overheating beyond the smoking point.

⚠ Never leave a chip pan unattended. Always heat fat slowly, and watch as it heats. Deep fry pans should be only one third full of fat. Filling the pan too full of fat can cause spill over when food is added. If you use a combination of oils or fats in frying, stir them together before heating, or as the fats melt.

Foods for frying should be as dry as possible. Frost on frozen foods or moisture on fresh foods can cause hot fat to bubble up and over the sides of the pan. Carefully watch for spills or overheating of foods when frying at high or medium high temperatures. Never try to move a pan of hot fat, especially a deep fat fryer. Wait until the fat is cool.

⚠ Do not use water on grease fires and never pick up a flaming pan. Turn off the controls and then smother a flaming pan on a surface unit by covering the pan completely with a well fitting lid or baking tray. If available, use a multi-purpose dry chemical or foam-type fire extinguisher.

Take care that no water seeps into the appliance.

Only certain types of glass, glass-ceramic, earthenware or other glazed containers are suitable for hotplate cooking; others may break because of the sudden change in temperature.

Cleaning

In the interests of hygiene and safety, the hob should be kept clean at all times as a build up of fats and other foodstuffs could result in a fire.

Clean only the parts listed in this guide.

Clean with caution. If a wet sponge or cloth is used to wipe spills on a hot surface, be careful to avoid steam burns. Some cleaners can produce noxious fumes if applied to a hot surface.

2. Hob Overview

Fig. 2.1

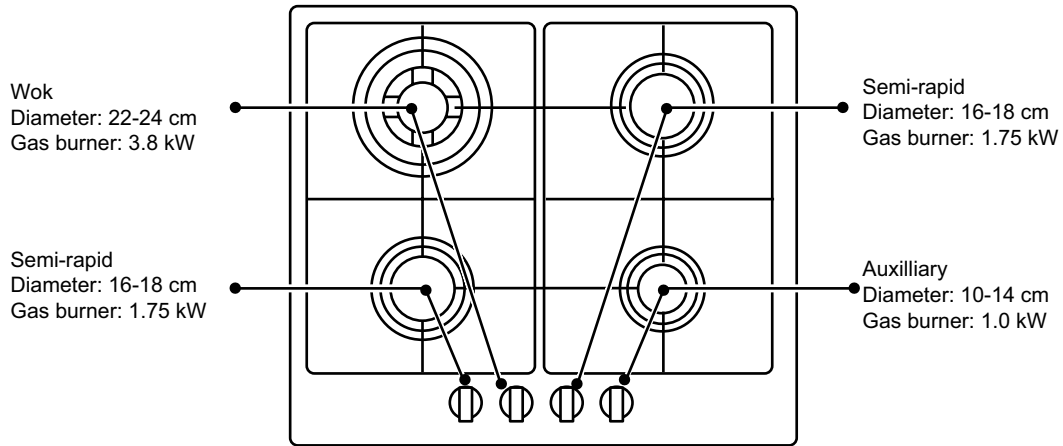

Type	Material	Power supply
RMB60HPNGFSS/	Stainless Steel	230V~50Hz

The diagram by each of the control knobs indicates which burner that knob operates (**Fig. 2.1**). Each burner has a special Flame Safety Device (FSD) that stops the flow of gas if the flame goes out.

To light a burner, push in and turn the associated control knob anti-clockwise (**Fig. 2.2**) to the 'high' position indicated by the large flame symbol [🔥]. Keep the knob pressed down for 3-5 seconds to let the gas through to the burner. The igniter should spark and light the gas.

If, when you let go of the control knob the burner goes out, then the safety device has not held in. Turn the control to the off position and wait one minute then try again, this time holding in the control knob for slightly longer.

Adjust the flame to suit by turning the control knob clockwise (**Fig. 2.3**).

Ensure that the flames are under the pans. Using a lid will help the contents boil more quickly (**Fig. 2.4**).

Large pans should be spaced well apart.

Fig. 2.2

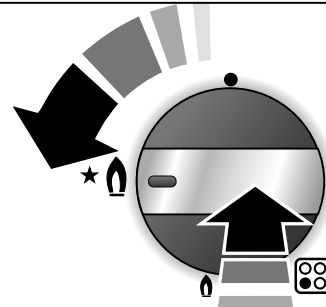

Fig. 2.3

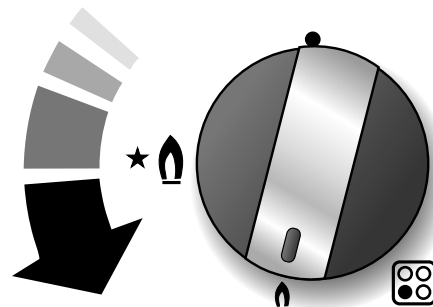

Fig. 2.4

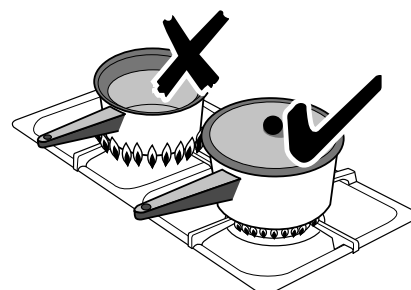
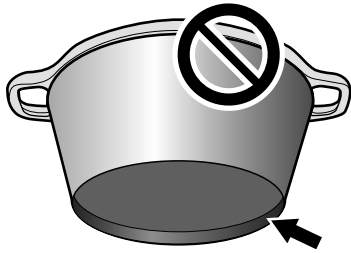

Fig. 2.5



Pans and kettles with concave bases or down turned base rims should not be used (Fig. 2.5).

Simmering aids, such as asbestos or mesh mats, are NOT recommended. They will reduce burner performance and could damage the pan supports (Fig. 2.6).

You should also avoid using unstable and misshapen pans that may tilt easily, and pans with a very small base diameter, e.g. milk pans, single egg poachers (Fig. 2.7).

The minimum recommended pan diameter is 120mm. The maximum allowable pan base diameter is 250mm.

Fig. 2.6

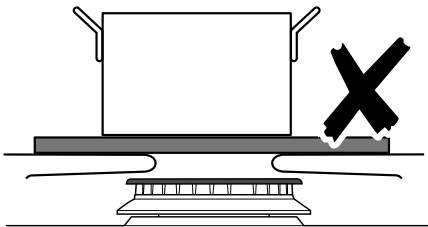

Wok Ring Burner

The wok ring burner is designed to provide even heat over a large area. It is ideal for large pans and stir frying. For heating smaller pans, the smaller hotplate burners may be more efficient.

Woks vary very widely in size and shape. It is important that the wok sits down on the pan support – however, if the wok is too small, the cradle will not support it properly (Fig. 2.8).

The cradle should be used on the wok burner only. When you fit the cradle, make sure that it is supported properly on a pan support and the wok is sitting level in the cradle (Fig. 2.9). The cradle will get very hot in use.

Fig. 2.7

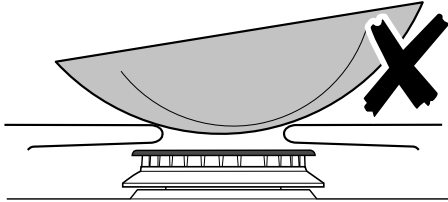
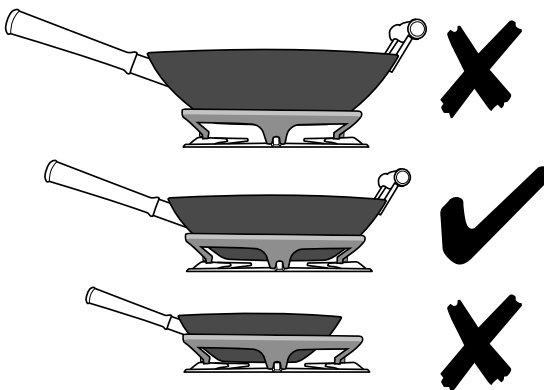

Fig. 2.8



Hob Care

The burner parts can be removed for cleaning; see 'Cleaning your hob'.

You should wipe the top surface of the hob around the hotplate burners as soon as possible after spills occur. Try to wipe any spills off while the hob is still warm.

NOTE: The use of aluminium pans may cause metallic marking of the pan supports. This does not affect the durability of the enamel and may be cleaned off with an appropriate metal cleaner.

Fig. 2.9

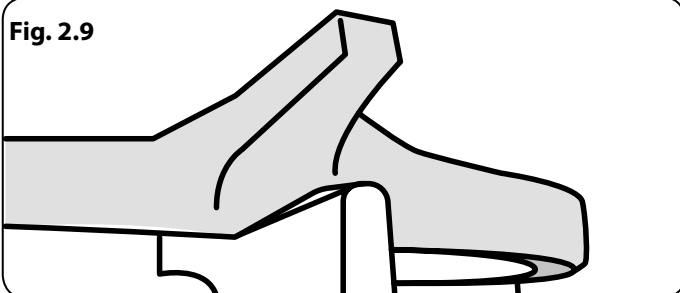

3. Cleaning Your Hob

Essential Information

Allow the cooker to cool and then isolate the electricity supply before carrying out any thorough cleaning.

⚠ Never use paint solvents, washing soda, caustic cleaners, biological powders, bleach, chlorine based bleach cleaners, coarse abrasives or salt.

⚠ Do not mix different cleaning products – they may react together with hazardous results.

All parts of the hob can be cleaned with hot soapy water – but take care that no surplus water seeps into the appliance.

Remember to switch on the electricity supply before re-using the cooker.

Regular cleaning is recommended. For easier cleaning, wipe away any spillages immediately.

Hotplate Burners

The burner heads and caps can be removed for cleaning.

⚠ DO NOT put the burner heads in a dishwasher.

Make sure they are absolutely dry before replacing them.

The Single Ring Burners

When refitting the burner head, ensure that the notch and opening lines up with the electrode in the base (**Fig. 3.1**). Check that the burner head is level and that the cap is fitted centrally on the burner head.

The Wok Ring Burner

The wok ring burner can also be taken apart for cleaning (**Fig. 3.2**).

When reassembling the burner (**Fig. 3.2**), the burner head (**C**) has two grooves which aligns with the FSD (**E**) and the Electrode (**F**).

Fit the 2 burner caps, making sure that they are seated properly.

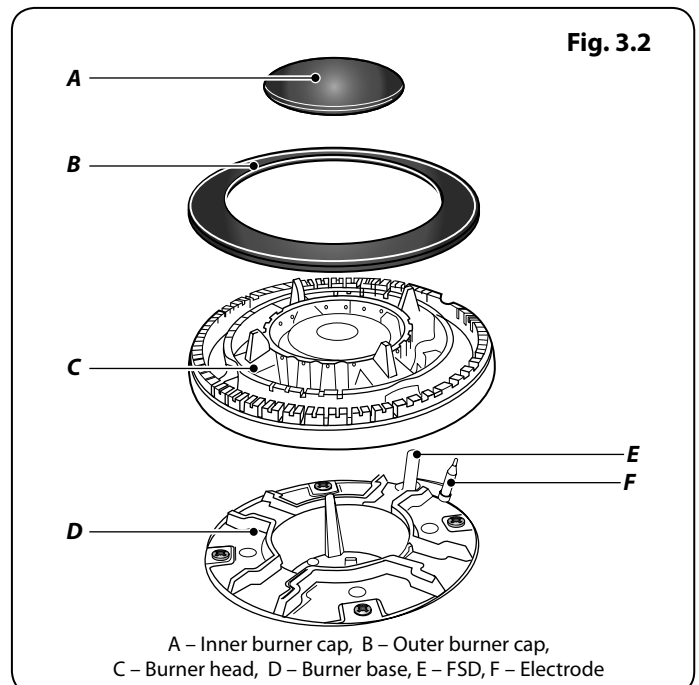
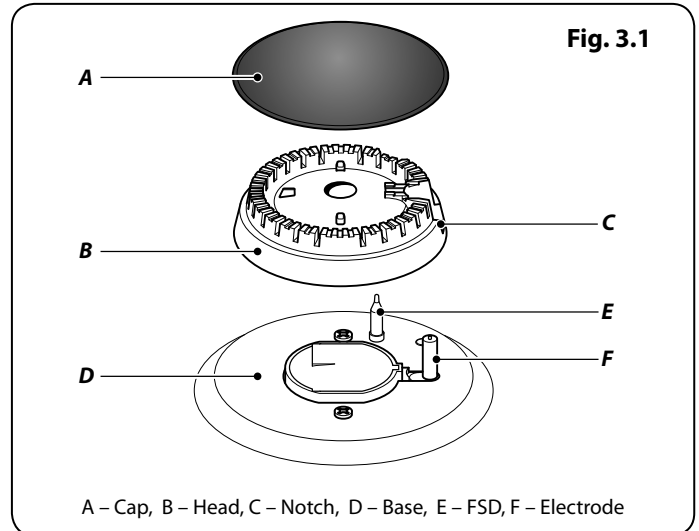

Cleaning Table

Refer to the cleaning tables (**Table 3.1 Cleaning the hotplate** and **Table 3.2 Cleaning outside the hotplate**) for details on cleaning the hob.

The cleaners listed are available from supermarkets or electrical retailers. For enamelled surfaces use a cleaner that is approved for use on vitreous enamel.

Part	Finish	Recommended cleaning method
<i>Hotplate top</i>	<i>Stainless steel or glass</i>	<i>Hot soapy water and a soft cloth. remove stubborn stains gently with a nylon scourer.</i>
<i>Pan supports</i>	<i>Enamel coated cast iron</i>	<i>Cream cleaner and a nylon scourer; dishwasher.</i>
<i>Burner caps</i>	<i>Enamel</i>	<i>Cream cleaner and a nylon scourer; dishwasher.</i>
<i>Burner heads</i>	<i>Aluminium</i>	<i>Cream cleaner or similar with a soft cloth. Take care not to be too vigorous.</i>

Table 3.1 Cleaning the hotplate

Part	Finish	Recommended cleaning method
<i>Control panel</i>	<i>Stainless steel or glass</i>	<i>Damp soft cloth. Do not use abrasive cleaners on the lettering.</i>
<i>Control knobs</i>	<i>Plastic and brushed aluminium</i>	<i>Damp soft cloth.</i>

Table 3.2 Cleaning outside the hotplate

4. Troubleshooting

If there is an installation problem and I don't get my original installer to come back to fix it, who pays?

You do. Service organisations will charge for their call-outs if they are correcting work carried out by your original installer. Therefore, it's in your own interest to keep track of this installer so that you can contact them as required.

Hotplate ignition or hotplate burners faulty

Is the power on? If not, there maybe something wrong with the power supply.

Are the sparker (ignition electrode) or burner slots blocked by debris?

Are the burner trim and caps correctly located? See the section on 'Cleaning'.

Hotplate burners will not light

Make sure that the burner parts have been replaced correctly after wiping or removing for cleaning.

Check that there is not a problem with your gas supply. You can do this by making sure that other gas appliances you may have are working.

Do the burners spark when you turn on the control? If not, check that the power is on.

INSTALLATION

Check the appliance is electrically safe and gas sound when you have finished.

5. Installation

Dear Installer

Before you start your installation, please complete the details below.

Installer's Name
Installer's Company
Installer's Telephone Number
Appliance Serial Number

⚠ This hob is a Class 3 appliance.

Should your customer have a problem relating to your installation they will be able to contact you easily.

You must be aware of the following safety requirements & regulations:

Before installing, make sure that the local distribution conditions (nature of the gas and gas pressure) and the adjustment of the appliance are compatible.

This appliance must be installed in accordance with the regulations in force and only in a well-ventilated space. Read the instructions before installing or using this appliance.

The regulations and standards are as follows:

In the UK

In your own interest and that of safety, it is law that all gas appliances be installed by competent persons. CORGI registered installers undertake to work to safe and satisfactory standards. Failure to install the appliance correctly could invalidate any warranty or liability claims and lead to prosecution.

⚠ This appliance should not be installed in a boat or caravan.

The hob must be installed in accordance with:

- All relevant British Standards / Codes of Practice, in particular BS 5440 Part 2
- For Natural Gas – BS 6172 and BS 6891
- For LP Gas – BS 5482-1 (when the installation is in a permanent dwelling)
- The Gas Safety (Installation and Use) regulations
- The relevant Building / IET regulations

In the Republic of Ireland

The installation must be carried out by a Competent Person and installed in accordance with the current edition of IS 813 "Domestic Gas Installations", the current Building Regulations and reference should be made to the current ETCI rules for electrical installation.

INSTALLATION

Check the appliance is electrically safe and gas sound when you have finished.

Provision of Ventilation

This appliance is not connected to a combustion products evacuation device. Particular attention shall be given to the relevant requirements regarding ventilation.

In the UK

The room containing the hob should have an air supply in accordance with BS 5440 Part 2. All rooms require an openable window or equivalent, while some rooms require a permanent vent in addition to the openable window. The hob should not be installed in a bed sitting room with volume less than 20m³. If it is installed in a room of volume less than 5m³ an air vent of effective area 100cm² is required; if it is installed in a room of volume between 5m³ and 10m³, an air vent of effective area 50cm² is required; while if the volume exceeds 11m³, no air vent is required.

If there are other fuel burning appliances in the same room, BS 5440 Part 2 should be consulted to determine the requisite air vent requirements.

In the Republic of Ireland

Reference should be made to the current edition of IS 813, which makes clear the conditions that must be met to demonstrate that sufficient ventilation is available.

Location of the Hob

The hob may be installed in a kitchen/kitchen diner but NOT in a room containing a bath or shower.

NOTE: An appliance for use on LPG shall not be installed in a room or internal space below ground level, e.g. in a basement.

Conversion

All models are supplied set for use on group H natural gas. A conversion kit for LP gas is included with the appliance. See the instructions that are supplied with the conversion kit. After converting the appliance please attach the Gas Conversion sticker over the appropriate area of the data badge; this will identify the gas type the appliance is now set for.

This appliance is designed for domestic cooking only. Use for any other purpose could invalidate any warranty or liability claim.

You will need the following equipment to complete the hob installation satisfactorily:

- Gas Pressure tester
- Flexible gas hose
- Multimeter

You will also need the following tools:

- Electric drill
- Jigsaw
- Steel tape measure
- Cross head screwdriver
- Pencil
- Adjustable spanner
- Sharp knife

Checking the Parts

Check that the appliance is in a good condition after having removed the packaging. In case of doubt, do not use the appliance and contact the retailer.

⚠ Never leave the packaging materials (cardboard, plastic bags, polystyrene foam, etc.) within children's reach since they could become potential sources of danger.

INSTALLATION

Check the appliance is electrically safe and gas sound when you have finished.

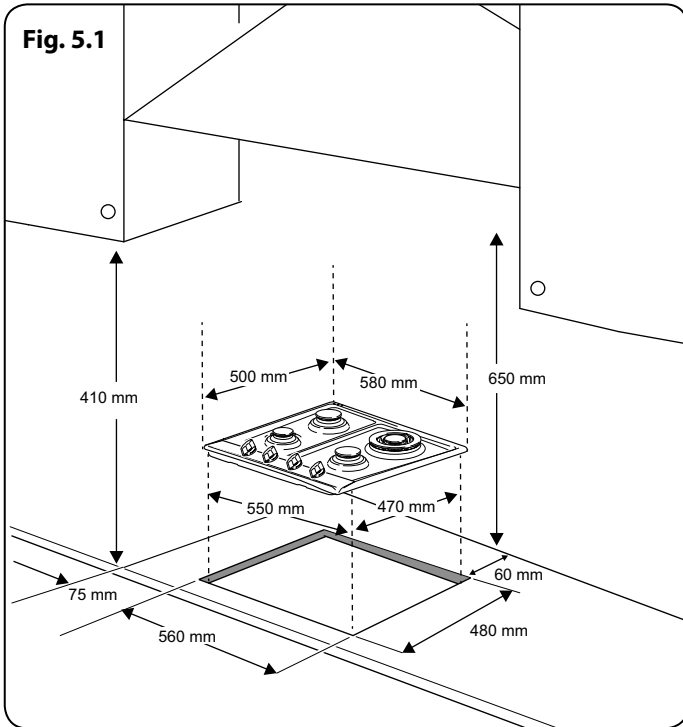

Positioning the Hob

It is recommended that the hob be installed in a worktop with a minimum thickness of 38 mm and depth of 600 mm. The cut-out dimensions and the recommended minimum clearances from the hob to nearby surfaces are shown in (Fig. 5.1) and (Fig. 5.2).

NOTE: If installing the hob over a standard cabinet, you may have to remove part of the cabinet panels to allow the unit to fit correctly.

NOTE: Gap between the cut-out and back of the wall **MUST** be 60 mm (Fig. 5.1).

If installing a built-in oven directly under the hob, a minimum thickness of 38 mm worktop is required and **must have an air gap of 10 mm** between the oven and the bottom of the hob (Fig. 5.2).

If no built-in oven is installed underneath, and if the worktop surface used has less than a 38 mm is used a **10 mm air gap is still required** (Fig. 5.2).

NOTE: If the built-in hob is being installed directly above a built-in oven, an additional spacer (not supplied) may be required to maintain a **clearance of 10 mm** between the underside of the built-in hob and the top of the built-in oven (Fig. 5.3).

⚠ There should be a minimum air gap of 10 mm under the hob. Failure to maintain a suitable clearance may impair the performance of the hob.

Any hob hood should be installed in accordance with the hood manufacturer's instructions.

Any splashback must be fitted in accordance with the manufacturers instructions. Allowance should be made for the additional height of the flue trim, which is fitted to the cooker hob.

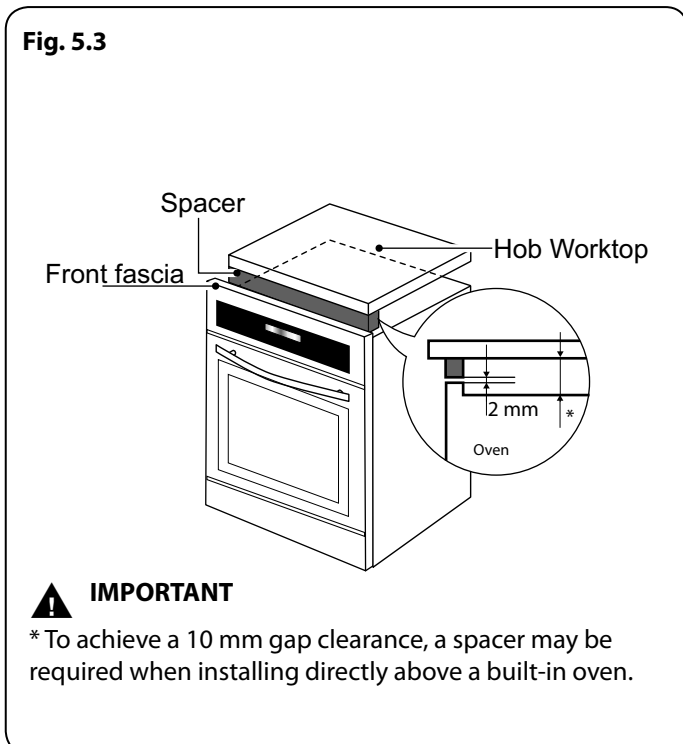
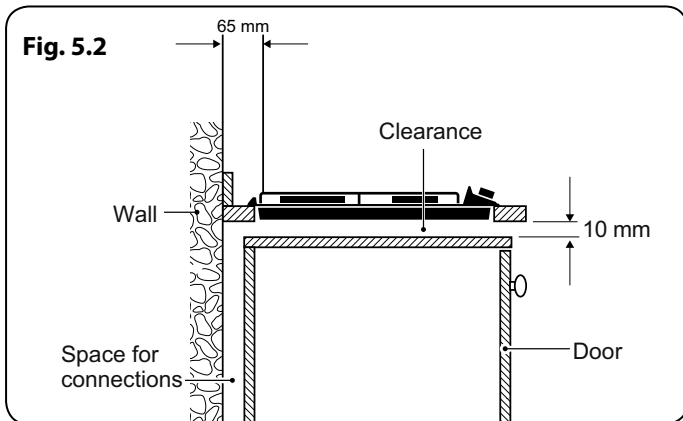

Surfaces of furniture and walls at the sides and rear of the hob should be heat, splash and steam resistant. Certain types of vinyl or laminate kitchen furniture are particularly prone to heat damage and discolouration.

We cannot accept responsibility for damage caused by normal use of the hob to any material that de-laminates or discolours at temperatures less than 65°C above room temperature.

For safety reasons curtains must not be fitted immediately behind the hotplate.

INSTALLATION

Check the appliance is electrically safe and gas sound when you have finished.

Fixing the seal to the back of the hob

The hob must be sealed to the work surface to prevent liquid from entering into the cabinet. A tape seal is supplied with the hob. Refer to **Fig. 5.4**.

1. Turn the hob over and place in on a secure, level surface.
2. Spread the longer seal "A" around the inner left, rear and right sides.
3. With a cutter or scissors cut the excess seal and retain for next use.
4. Spread the seal "B" around the left, front and right outer edges of the cooktop.
5. Spread the seal "C" along the rear edge of the cooktop. Making sure that the beginning and the end overlap at the seal "B".

Fastening the Installation Brackets

Each cooktop is provided with an installation kit including brackets and screws for fastening the top to fixture panels from 20 to 40 mm thick. Refer to **Fig. 5.4**.

1. Turn the cooktop upside down and fasten the brackets "F" and "R" to the appropriate socket holes, without tightening the screws for the moment.
2. Make sure that the brackets are fastened.

Installing the Hob

1. Turn the hob back the right way up and position it in the worktop cut-out.
2. Insert the cooktop into the hole and position it correctly.
3. Adjust the position of the brackets "F" and "R" and tighten the "Rear Screw" and "Front Screw" to lock the cooktop firmly in position (**Fig. 5.5**).
4. With a sharp cutter or trimmer knife trim the excess sealing material around the edge of the cooktop. Take care not to damage the workbench.

If the surface that the hob is to be fitted is tiled, or is not reasonably smooth, additional sealing with a waterproof silicone sealant may be required.

INSTALLATION

Check the appliance is electrically safe and gas sound when you have finished.

Fig. 5.4

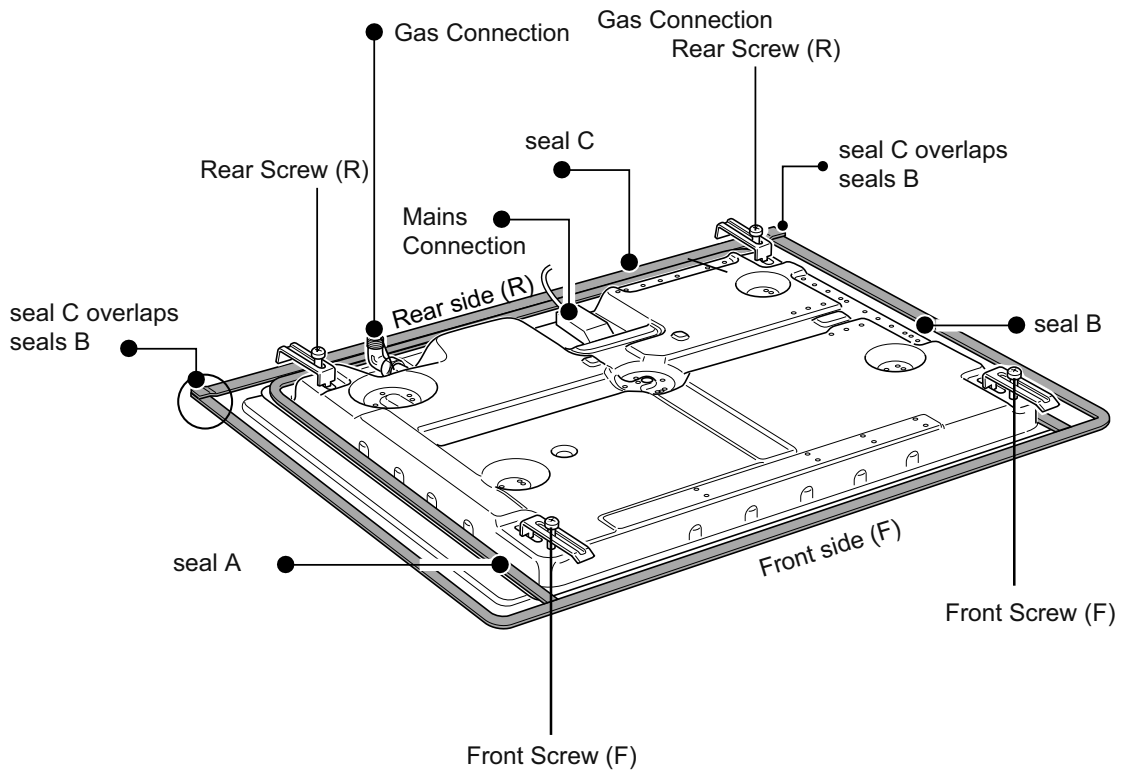
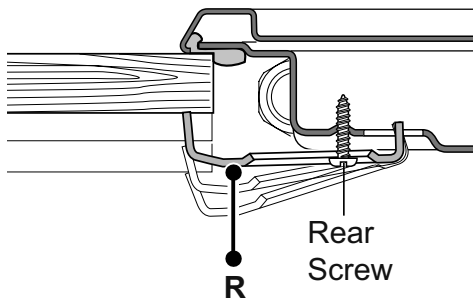
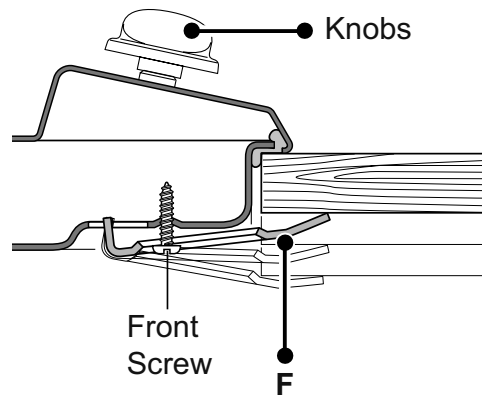

Fig. 5.5

Rear side



Front side



WARNING – SERVICING TO BE CARRIED OUT ONLY BY AN AUTHORISED PERSON
Disconnect from electricity and gas before servicing. Check appliance is safe when you have finished.

6. Conversion to LPG

Check in the 'Technical Data' section at the back of the instructions that the hob is convertible to the gas you want to use.

- ⚠ This conversion must be performed by a suitably competent person, in accordance with these instructions and with the local supply company requirements.**
- ⚠ Failure to convert the appliance correctly could invalidate any warranty or liability claims and lead to prosecution.**
- ⚠ The conversion instructions must be used in conjunction with the rest of the appliance instruction, in particular for information on Standards, cooker positioning, connection, hose suitability, etc.**
- ⚠ When servicing or replacing gas-carrying components, disconnect from the gas before starting, and check that the appliance is gas sound after completion.**
- ⚠ Do not use reconditioned or unauthorised gas controls.**
- ⚠ Disconnect from the electricity supply before commencing servicing.**
- ⚠ Before electrical reconnection, check that the appliance is electrically safe.**

Injectors

To replace the injectors proceed as follows:

1. Remove the pan supports, the burner and caps.
2. Using a socket spanner unscrew "J" (**Fig. 6.1**) and (**Fig. 6.2**).
3. Choose the injectors to be replaced according to the data in the "Technical Data" chapter. The injector diameter, expressed in hundredths of a millimetre, is marked on the injector body.

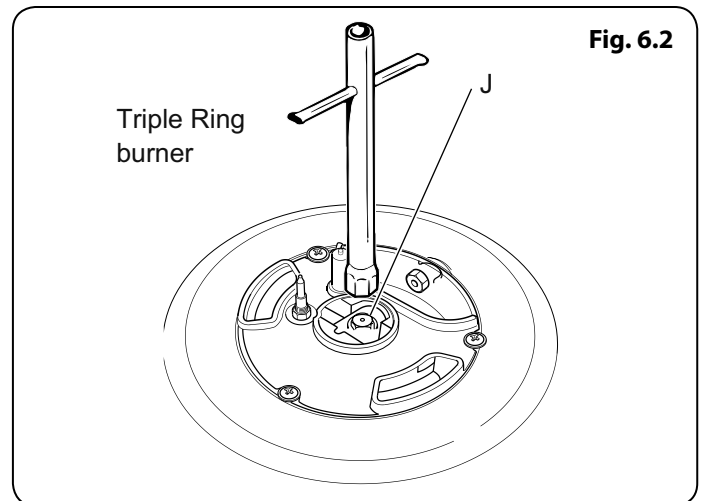
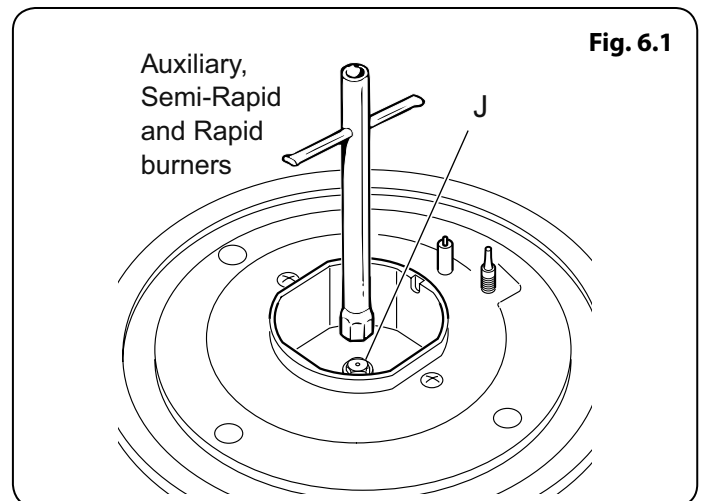

WARNING – SERVICING TO BE CARRIED OUT ONLY BY AN AUTHORISED PERSON
Disconnect from electricity and gas before servicing. Check appliance is safe when you have finished.

Fig. 6.3

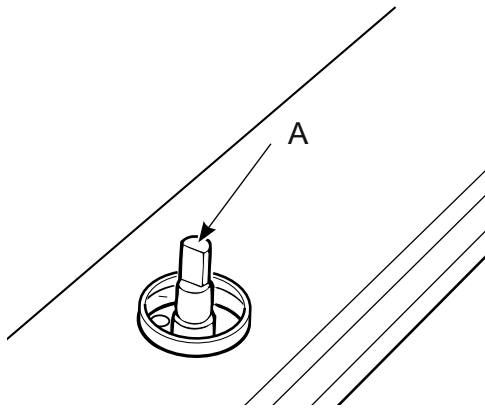

Tap Adjustment

Disconnect from the electricity supply.

When changing from one type of gas to another, the minimum tap output must also be correct, considering that in this position the flame must be about 4 mm long and must remain lit even when the knob is turned sharply from the maximum to the minimum position.

The adjustment is performed with the burner lit, as follows:

1. Turn the knob to the minimum position.
2. Remove the tap knob.
3. Turn the screw "A" to the correct setting (**Fig. 6.3**).

For LPG, tighten the adjustment screw completely.

Affix Label

Stick the LP gas label over the natural gas part of the appliance data label.

Pressure Testing

Make sure that the appliance is gas sound.

The gas pressure can be measured at one of the hotplate burner injectors (not the Wok burner). Lift off a burner head. Fit the pressure gauge to the injector. Turn on and light one of the other hotplate burners. Turn on and push in the control knob for the burner with the pressure gauge fitted to let gas through.

Refer to the "Connections" table in the "Technical Data" for pressure settings

Turn off the burners. Reassemble burner top, making sure it is reassembled in the correct way on the burner body.

Lubrication of the Gas Taps

The operations must be executed by a qualified technician.

⚠ IMPORTANT: All intervention regarding installation maintenance and conversion of the appliance must be fulfilled with original factory parts. The manufacturer declines any liability resulting from the non-compliance of this obligation.

INSTALLATION

Check the appliance is electrically safe and gas sound when you have finished.

Conversion to LP

If the appliance is to be converted to LP gas do the conversion at this point. See the conversion section of these instructions.

Gas Connection

Before connecting the appliance, check that it is suitable for your gas and electricity supply. This information is on the data label fixed to the underside of the hotplate. Gas connection must comply with the relevant standards and regulations in force.

The gas connection point is located towards the rear of the hob. The inlet union is Rp ½.

The appliance must be connected to the gas supply system with one of the following:

A rigid steel pipe

The joints of this pipe must consist of threaded fittings conforming to the standards. The use of seals such as hemp with suitable cement, or Teflon tape, is permitted.

A copper pipe

The joints of this pipe must consist of unions with mechanical seals.

A flexible hose

A hose is not supplied with the hotplate. Hoses may be purchased at most builders' merchants.

The hose should be fitted so that both inlet and outlet connections are vertical so that the hose hangs downwards.

The hose must be in accordance with the relevant standards. In the UK these are:

For Natural Gas the flexible hose must be in accordance with BS 669.

For LP Gas it should be capable of 50mbar pressure, 70°C temperature rise and carry a red stripe, band or label.

INSTALLATION

Check the appliance is electrically safe and gas sound when you have finished.

Fig. 6.1

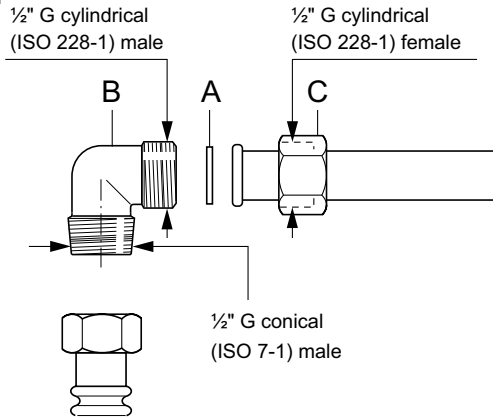

Connection to the Gas Supply

Gas connection (GB) Cat: II 2H3+

The fitting (**Fig. 6.1**) is made up of:

- Nut "C"
- Elbow fitting "B"
- Gasket "A"

⚠ Be careful when flexible pipes are used that they do not come into contact with moving parts.

⚠ IMPORTANT! Do not use a naked flame to test for leaks.

To maintain the thickness of 30 mm, the hob is fitted with a channel to contain the connection pipe.

The gas inlet union can be turned in the direction required after the elbow fitting "B" and nut "C" connection (**Fig. 6.1**) has been slackened (**Fig. 6.2**).

⚠ Never put the gas inlet in a downward position.

⚠ Never attempt to turn the elbow "B" without having first slackened off the relative lock nut "C".

The gasket "A" (**Fig. 6.1**) guarantees the seal of the gas connection. It is recommended that it be replaced whenever it shows even the slightest deformation or imperfection.

Fig. 6.2

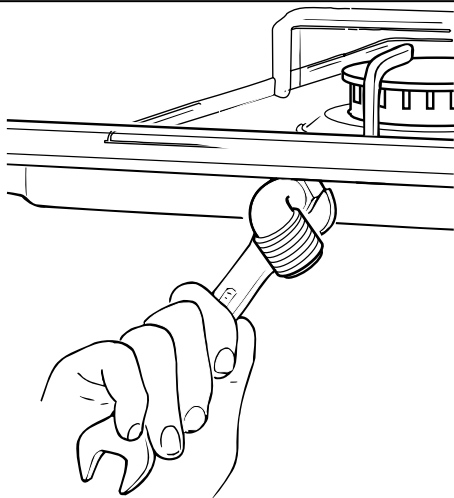

INSTALLATION

Check the appliance is electrically safe and gas sound when you have finished.

Safety Information

Ensure that the gas supply pipe is never able to touch moveable parts of the built-in cabinet (e.g. drawers). It must not pass through compartments that could be used for storage purposes.

When using a flexible hose, it is essential to comply with the following instructions:

- No part of the pipe must be able to touch parts the temperature of which exceeds 75°C
- The pipe must not be pulled or twisted, throttled or tightly bent.
- It must not come into contact with sharp edges or corners.
- It must be easy to inspect the entire pipe length in order to check its state of wear.
- The pipe must be replaced within the date stamped on the pipe itself.

If in doubt, contact your supplier.

After completing the gas connection check the hotplate is gas sound with a pressure test.

Pressure Testing

The gas pressure can be measured at one of the hotplate burner injectors (not the Wok burner). Lift off a burner head. Fit the pressure gauge to the injector. Turn on and light one of the other hotplate burners. Turn on and push in the control knob for the burner with the pressure gauge fitted to let gas through.

Refer to the "Connections" table in the "Technical Data" for pressure settings

Turn off the burners. Reassemble burner top, making sure it is reassembled in the correct way on the burner body.

Electrical Connections

This appliance must be installed by a qualified electrician to comply with the relevant Institute of Electrical Engineers (I.E.T.) regulations and also the local electricity supply company requirements.

⚠ WARNING: THIS APPLIANCE MUST BE EARTHED

NOTE: All external wiring must comply with the IET Regulations for the Electrical Equipment of Buildings. This appliance must be connected by a competent person using fixed wiring via a double pole switched fused spur outlet, protected by a 3A fuse. The hob is supplied with a 3-core cable, 900mm long.

This appliance must be installed with the supplied cable, if a longer cable is required it must match the same specification or higher.

Plug Connection

For a plug connection a three-pin plug to BS 1363 with a capacity of not less than 13A must be used and fitted with a 3A fuse, 'ASTA' approved to BS 1362.

After replacing the fuse the cover must be refitted. If the cover is lost, the plug must not be used until a replacement cover has been obtained from your supplier. The colour of the correct fuse carrier is that of the coloured insert in the base of the fuse recess, or stated elsewhere on the plug. Always state this colour when ordering a replacement fuse carrier.

⚠ IMPORTANT: The wires in the mains lead are coloured in accordance with the following code:

- Green and yellow: Earth
- Blue: Neutral
- Brown: Live

Hotplate checks

Check each burner in turn. There is a spark ignition system that works when the knob is pressed in. Each burner also has a special safety device that stops the flow of gas if the flame goes out.

Push in and turn a control knob to the large flame symbol [H].

Keep holding the knob pressed in to let the gas through to the burner for few seconds. The igniter should spark and light the gas.

If, when you let go of the control knob, the burner goes out, the safety device has not held in. Turn the control to the off position and wait one minute, then try again this time holding in the control knob for slightly longer.

Customer Care

Please complete your contact details in the front of this section. Please inform the user how to operate the hotplate and hand over the instruction pack.

Thank you.

7. Circuit Diagram

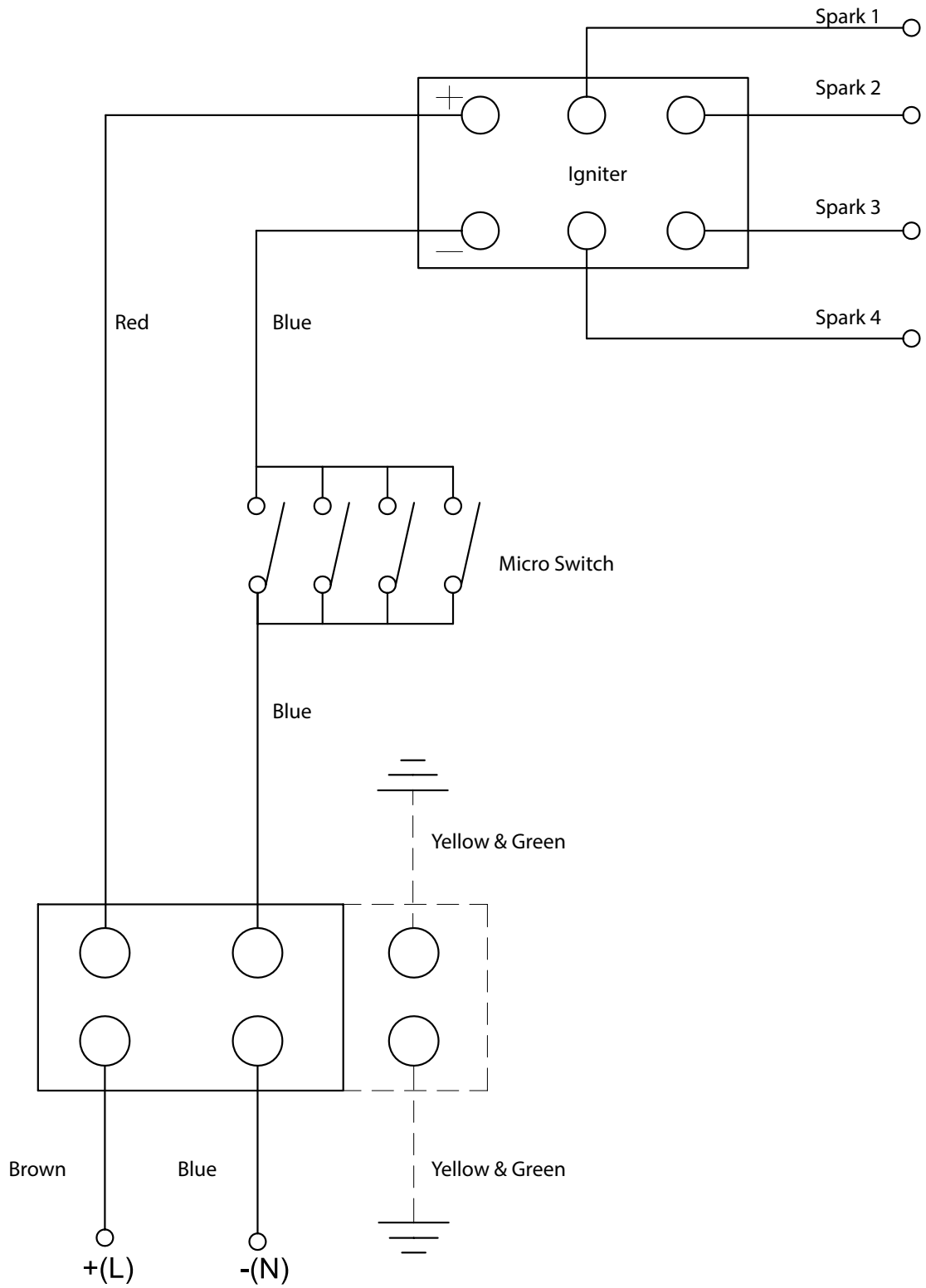

8. Technical Data

The hob is an independent Class 3 built-in unit.

This hob is category II₂H₃+

It is supplied set for group H natural gas. A conversion kit from NG to LP is available for the hob.

INSTALLER: Please leave these instructions with the user.

DATA BADGE LOCATION: Base of the hob.

COUNTRY OF DESTINATION: GB/IE

Connections

Gas	Electric
Rp ½ at rear right-hand side	230V~50Hz

Gas		Electric
Natural Gas	20 mbar	230V~50Hz
Butane	29 mbar	
Propane	37 mbar	

(See appliance data badge for test pressures)

Dimensions

	Outside	Inside
Width	580 mm	550 mm
Length	500 mm	470 mm
Depth	50 mm from top	40 mm
Mass (kg)	10	
Space for fixing	See Positioning of the Hob "Fig. 5.1" on page 10	
Minimum space above hotplate	See Positioning of the Hob "Fig. 5.1" on page 10	

Ratings

Hotplate	Natural Gas		L.P. Gas	
		Injector		Injector
Wok Burner	3.8 kW	135	3.8 kW (277 g/h)	98
Semi-rapid Burners	1.75 kW	97	1.75 kW (127 g/h)	65
Auxilliary Burner	1.0 kW	72	1.0 kW (73 g/h)	50

Gas burner inputs based on Gross Calorific Value



Hotplate Efficiency

Brand	Rangemaster
Model Identification	RMB60HPNGFSS/
Size (mm)	580
Type	Gas

Type of Hob	GAS
Number of gas burners	4
Auxiliary / Small Burner (EE gas burner)	-
Semi-rapide / Medium Burner (EE gas burner)	56.35 %
Semi-rapide / Medium Burner (EE gas burner)	57.98 %
Wok (EE gas burner)	56.26 %
Hotplate EE gas hob	56.86 %
In accordance with Reg. (EU) No 66/2014 (Implementing 2009/125/EC)	

9. Warranty/After Sales Service

If consultation or technical assistance is needed, please provide the local authorised service agent with the purchase invoice and the product code/serial number.

The 2 years free maintenance for the operation of the appliance started from the date of purchase of this product.

Any cosmetic damage to the appliance must be reported within 90 days of delivery.

Please note that AGA Rangemaster Limited have appointed UK Warranty Solutions to administer in warranty repairs on our behalf. If you make a request for an in warranty repair, your details will be held by Warranty Solutions.

NOTE

NOTE

NOTE

NOTE

NOTE

AGA RANGEmaster

Clarence Street, Royal Leamington Spa,
Warwickshire, CV31 2AD, England.

Tel: +44 (0) 800 8046261

E-mail: consumers@agarangemaster.co.uk

