

N 50, INDUCTION HOB WITH INTEGRATED VENTILATION SYSTEM, 60 CM, SURFACE MOUNT WITHOUT FRAME
V56NBS1LO

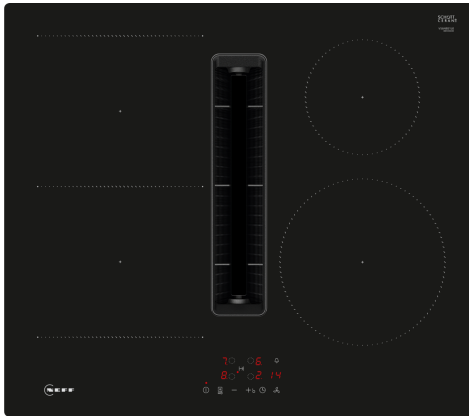

B

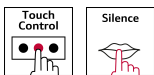

Included accessories

1 x Slider for unducted recirculation, 1 x Clean Air Plus odor filter

Optional accessories

Z811DU0 Acoustics Filter, Z821PD1 Plinth Diffusor, Z821VR1 Clean Air Plus odor filter (replacement), Z861KE1 Exhaust kit, Z861KR0 Recirculation kit 2 L-bow (70cm), Z861KR1 Recirculation kit S and L-bow (60cm), Z861KR2 Recirculation kit 1x L-bow, Z861SB1 90° flat duct bend horizontal, Z861SB2 90° flat duct L vertical, Z861SB3 90° flat duct M vertical, Z861SB4 90° flat duct S vertical, Z861SI0 Adapter round-flat, Z861SI1 90° Adapter round-flat, Z861SM1 Straight tube 500mm, Z861SM2 Straight tube 1000mm, Z861SS1 Connector sleeve (female), Z861SS2 Flex sleeve (female), Z9404SE0 4 pieces Set, Z9406SE0 6 pieces Set, Z9410ES0 Espresso maker 4 cups, Z9428FE0 Iron pan Ø 18 / 28 cm, Z943SE0 Set of 2 pots and 1 pan

This induction hob with integrated ventilation combines two appliances in one for a clear view while cooking.

- ✓ Touch Control – Control your hob with just one touch and a timer.
- ✓ Combi Induction – offers 2 individual induction cooking zones or 1 large combined induction cooking zone.
- ✓ High Extraction Rate – ensures a clear view while cooking thanks to efficient motor technology.
- ✓ Reduced Noise – our optimized motor guarantees a quiet cooking experience.
- ✓ Easy-clean filters – Easy to remove and dishwasher-safe.

Features

Technical Data

Product name/family: Cooking zone ceramic
 Construction type: Built-in
 Energy input: Electric
 Min. required niche size for installation (HxWxD): 223 x 560-560 x 490-490 mm
 Width of the appliance: 592 mm
 Dimensions: 223 x 592 x 522 mm
 Dimensions of the packed product (HxWxD): . 431 x 697 x 672 mm
 Net weight: 21.8 kg
 Gross weight: 26.6 kg
 Residual heat indicator: Separate
 Location of control panel: Front
 Basic surface material: Ceramic
 Color of surface: Black
 Length of electrical supply cord: 110.0 cm
 Sealed Burners: No
 heating with booster: All
 Power of 2nd heating element (kW): 3.6 kW
 Power of 5th heating element (kW): 1.4 kW
 Maximum output air extraction: 500 m³/h
 Boost position output recirculating: 595.0 m³/h
 Maximum output recirculating air: 441 m³/h
 Boost position air extraction: 622 m³/h
 Noise level: 69 dB(A) re 1 pW
 Odour filter: No
 Voltage: 220-240/380-415 V
 Frequency: 50-60 Hz
 Length of electrical supply cord: 110.0 cm
 Min. required niche size for installation (HxWxD): 223 x 560-560 x 490-490 mm
 Dimensions: 223 x 592 x 522 mm
 Dimensions of the packed product (HxWxD): . 431 x 697 x 672 mm
 Net weight: 21.8 kg
 Gross weight: 26.6 kg
 Included accessories: 1 x Slider for unducted recirculation, 1 x Clean Air Plus odor filter
 Delay Shut off modes: 30R_12E min



N 50, INDUCTION HOB WITH INTEGRATED VENTILATION SYSTEM, 60 CM, SURFACE MOUNT WITHOUT FRAME V56NBS1LO

Features

- 60 cm: space for 4 pots or pans.

Flexibility of cooking zones

- Combi zone
- : use bigger cookware by connecting two classic cooking zones into one large zone.
- Cooking zone front left: 190 mm, 210 mm, 2.2 KW (max. power 3.7 KW)
- Cooking zone rear left: 190 mm, 210 mm, 2.2 KW (max. power 3.7 KW)
- Cooking zone rear right: 145 mm , 1.4 KW (max power 2.2 KW)
- Cooking zone front right: 210 mm, 2.2 KW (max. power 3.7 KW)

Usage convenience

- Touch control: control the power with imprinted +/- touch buttons.
- Variable 17-stage power settings for each zone: precisely adapt the heat with 17 power levels (9 main levels and 8 intermediate levels).
- Switch-off timer: switches off the cooking zone at the end of the time set (e.g. for boiled eggs).
- Count-down Timer: an alarm sounds at the end of the time set (e.g. for pasta).

Time saving & efficiency

- Power Boost function for all zones
- : boil water faster thanks to 50% more energy than at the highest standard level.
- QuickStart function: when switching on, the hob automatically selects the cooking zone with cookware (when placed on a zone whilst the hob is off).
- ReStart function: in case of unintentional switch-off, this feature restores all previous settings by switching on the hob again within 4 seconds.
- Quick-Off: quickly switch off a cooking zone with one longer touch.

Design

- Frameless

Safety

- 2 stage residual heat indicators: indicates which cooking zones are still hot or warm.
- Control panel lock: prevent unintended activation of the hob.
- Main switch: switch off all cooking zones at the touch of a button.
- Safety cut out facility: for safety reasons, heating stops after a preset time if not used (possible to customise).

Installation

- Dimensions of the product (HxWxD mm): 223 x 592 x 522
- Required niche size for installation (HxWxD mm) : 223 x 560 x (490 - 490)
- Min. worktop thickness: 16 mm
- Connected load: 7.4 KW
- 4.6kW power output (20A); current management options for 16A, 13A or 10A connection: limit the maximum power if needed (depends on fuse protection of electric installation).

Accessories

- Clean Air Plus odor filter, Slider for unducted recirculation included
- Suitable for installation into a 60 cm base cabinet

Integrated ventilation downdraft system

- Induction cooktop with fully integrated high-performance downdraft extractor.
- Suitable for ducted or recirculated extraction configuration (incl. differentiated software modes). Installation accessories for unducted recirculation, among these four cleanAir odor filters and a telescopic slider element, are included in the cooktop. Accessories for other installation options are available, details in the planning notes.
-
- Aesthetically integrated fully flush air intake design with floating, heat resistant glass ceramics element for free movement and placement of cookware.
- Ventilation system with 3 electronically controlled fan power levels and 1 Boost-/Intensive fan power levels (with automatic revert) via Touch control user interface
- - Automatic switch-on of ventilation system when a cooking zone is used.
- - Automatic delayed shut-off after cooking to erase residual odors after cooking (in specific ultra low-noise fan level, 12min in ducted extraction, 30min in recirculated extraction, can be shut-off manually).
- - Fully manual control possible via Touch control.
- High-performance, low-noise blower with energy-efficient BLDC-technology. High extraction rates at very low noises with pleasant noise frequencies through psycho-acoustically and aerodynamically optimized interior with enclosed, non-visible blower. Highly pressuredrop resistant even with longer and more complex ductings.
- Easy-to-detach and easy-to-clean grease filter and liquid collector unit:
- - Convenient one-hand removal of unit via floating glass ceramics handle.
- - Integrated, large-scale, high performance stainless-steel grease filters with 12 filtration layers and one black top layer for enhanced aesthetical integration. Grease filtration efficiency of 94 %.
- - All parts of the unit are easy-to-clean, fully dishwasher safe and heat resistant.
- - (Upper) Liquid collector unit with 200ml of capacity for standard accidental spillages or cooking condensate.
- - Powerful drainage system for spillages that exceed 200ml of liquids.
- - Liquid safety collector with additional capacity of 700ml for more severe accidental situations. Dishwasher safe. Easily accessible and detachable from below.
- - Overall capturing capacity of 900ml (200ml + 700ml).
- - Watertight blower system.
- Ventilation system performance:
- - Extraction performance in ducted extraction (according to EN

Features

61591): min. normal setting 330 m³/h , max. normal setting 500 m³/h , max. Boost-/Intensive setting 622 m³/h .

- Extraction performance in recirculated extraction (according to EN 61591): min. normal setting 252 m³/h , max. normal setting 441 m³/h , max. Boost-/Intensive setting 595 m³/h.
- Noise level in ducted extraction (Sound power level according to EN 60704-3): min. normal setting 61 dB re 1 pW, max. normal setting 69 dB re 1 pW, max. Boost-/Intensive setting 74 dB re 1 pW.
- Noise level in recirculated extraction (Sound power level according to EN 60704-3.): min. normal setting 55 dB re 1 pW, max. normal setting 66 dB re 1 pW, max. Boost-/Intensive setting 72 dB re 1 pW.
- Grease filter efficiency (according to EN 61591) 94 %.
- Consumption data and energy efficiency (according to Regulation (EU) No 65/2014):
- Energy Efficiency Class: B (at a range of energy efficiency classes from A+++ to D).
- Fluid Dynamic Efficiency: A .
- Average energy consumption: 57 .
- Grease filtration efficiency class: B .
- Noise min. normal setting & max. normal setting: 61 dB & 69 dB .
- For recirculation configuration: 2 x 2 battery of directly integrated, high-performance cleanAir odor filters.
- Optimised odour reduction performance for cooking applications with complex odour molecules (e.g. fish).
- Large scale filter surface with high odour reduction capabilities.
- Anti-pollen functionality: The filter retains an extremely high amount of airborne pollen and deactivates allergens which are retained by the filter.
- Lifetime of 360 hours of cooking (non-regenerative).
- Low-noise filters with optimised psycho-acoustics.
- Easy-to-access and easy-to-remove from above.
- Replenishment cleanAir filter set Z821VRO.
- For ducted extraction configuration: 2 x 2 sets of directly integrated, high-performance low-noise acoustic filters for significantly lower noise and improved psycho-acoustics.

Planning & installation notes

- Suitable for ducted or recirculated extraction installations in 4 different options (unducted, partly and fully ducted recirculation or ducted extraction). Installation accessories for unducted recirculation, among these four cleanAir odor filters and a telescopic slider element, are included in the cooktop. The included accessories allow easy and quick installations and can be planned in all worktop depths ≥ 60 cm. For other types of installation, one of the following accessory kits is recommended:
- Z861KR1 for partly-ducted recirculation in worktops of ≥ 60 cm depth with max. worktop height of 960 mm. Z861KR0 for partly-ducted recirculation in worktops of 70cm depth of ≥ 70 cm depth with max. worktop height of 960 mm.
- Z861KE1 as starter kit for ducted extraction in worktops of ≥ 60 cm depth.
- To complete the fully ducted extraction or to do any other individual recirculation planning different ducting accessories are available.
- Planning suggestions:
- Installation is possible in island as well as wall oriented configurations.
- The product and its accessories comply with the Needle Flame Test

(according to IEC 60695-11-5) and the V2 flammability class (according to UL94).

- The max. immersion depth is 223 mm below worktop surface.
- The appliance must be freely accessible from below (i.e. for accessing the lower liquid safety collector).
- No false floor is necessary below the cooktop with integrated downdraft ventilation system. The drawers and/or shelves in the floor unit must be removable. The backpanel of the floor unit can be kept - only a cut-out for the air outlet is needed (position and size can be taken from the installation instructions).
- An installation with unducted recirculation requires a vertical aperture of min. 25mm behind the backpanel of the furniture. Suggested for ideal performance are 50mm.
- The minimum worktop thickness is 16 mm for top mounted and flush installed appliances with the standard installation system. Installation in even thinner worktops is also possible with the spare part: content 626792.
- The overall appliance weight is 26kg - the bearing capacity and stability, in the case of very thin worktops in particular, must be supported using suitable substructures. The overall appliance weight and the worktop manufacturer's structural integrity specifications are to be taken into account.
- For partly ducted and unducted recirculation extraction installations, a return-flow aperture of ≥ 400 cm² is to be respected in the plinth area. The aperture can be realized via outlet grids, lamella grids or subtly shortened plinths depending on the assortment of the kitchen furniture manufacturer.
- The air outlet on the backside of the appliance can directly be accessed with a male flat duct element (DN 150).
- The pressuredrop resistant blower allows longer and more complex ductings up to 8m with three 90° bows while keeping sufficient performance.
- When installing a ventilation hood with ducted extraction and a chimney-vented fireplace, the power supply line of the appliance needs a suitable safety switch. This is not required for configurations in recirculated extraction.
- In ducted extraction configuration a one-way flap (or backflow trap) with a maximum opening pressure of 65Pa should be installed.

N 50, INDUCTION HOB WITH INTEGRATED VENTILATION SYSTEM, 60 CM, SURFACE MOUNT WITHOUT FRAME
V56NBS1LO

Dimensioned drawings

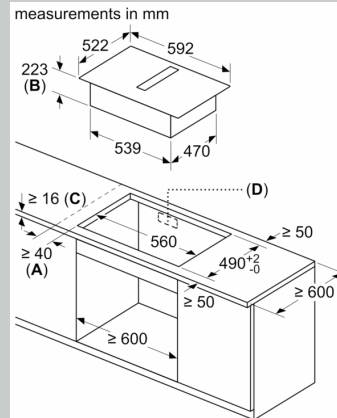
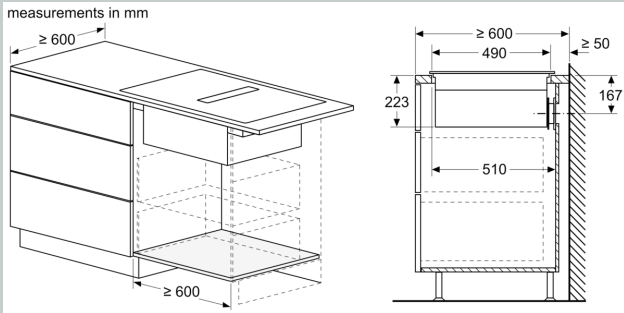

- A:** Minimum distance from the hob cut-out to the wall
- B:** Recessing depth
- C:** The worktop into which the hob is installed must withstand loads of approx. 60kg; suitable substructures must be used if required.
- D:** Cut-out in back panel required for pipework. Exact size and position can be taken from specific drawing.

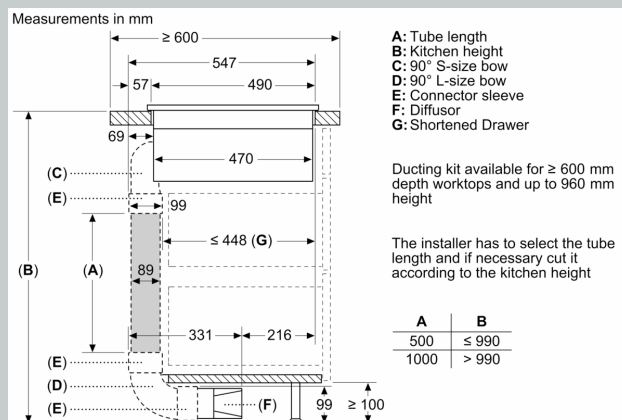
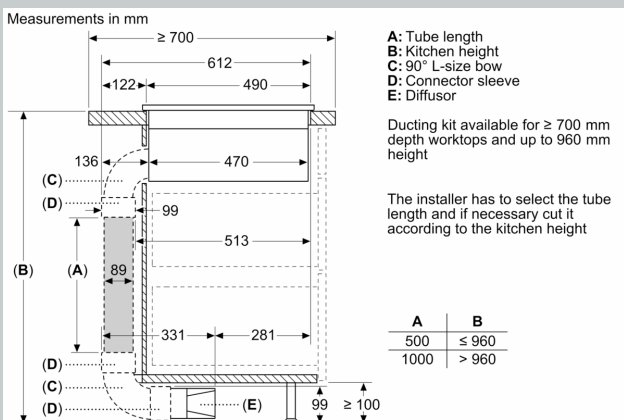

Dimensioned drawings

measurements in mm

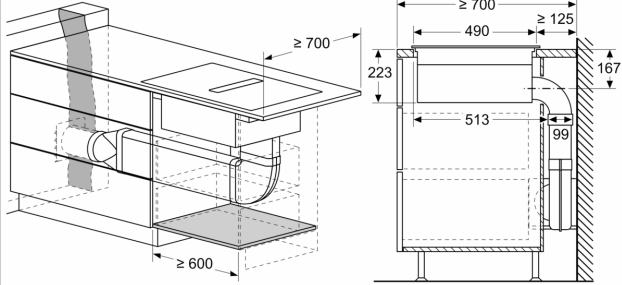

measurements in mm

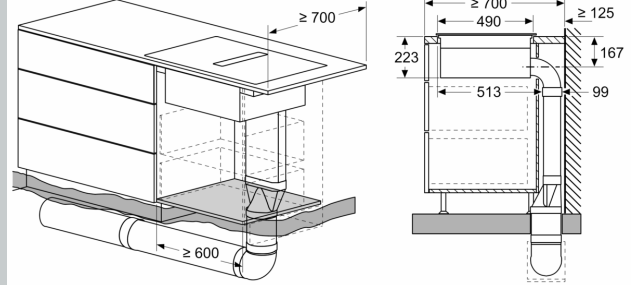

measurements in mm

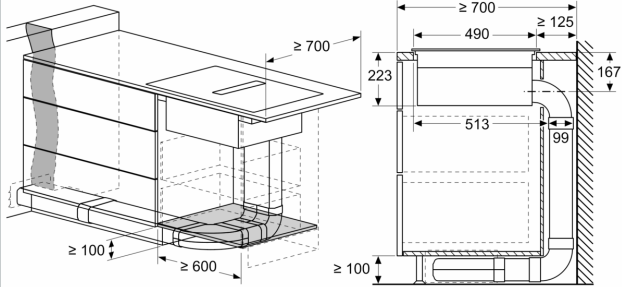

measurements in mm

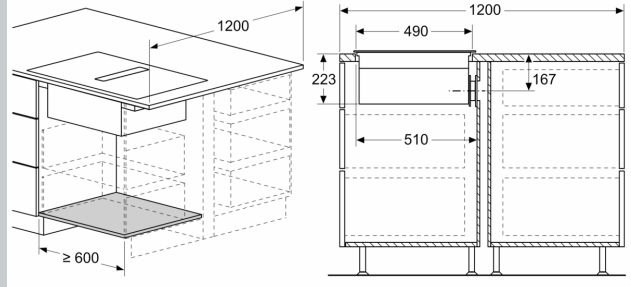

measurements in mm

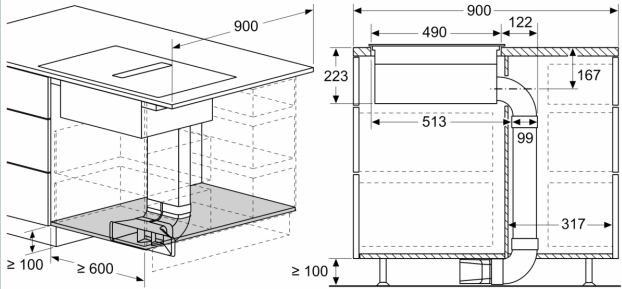

Measurements in mm

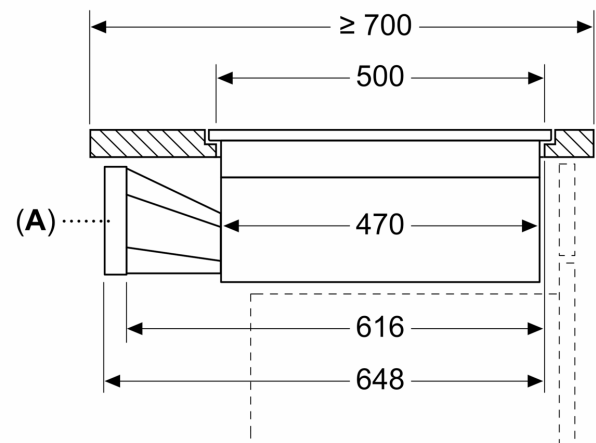

A: Adapter round-flat

Dimensioned drawings

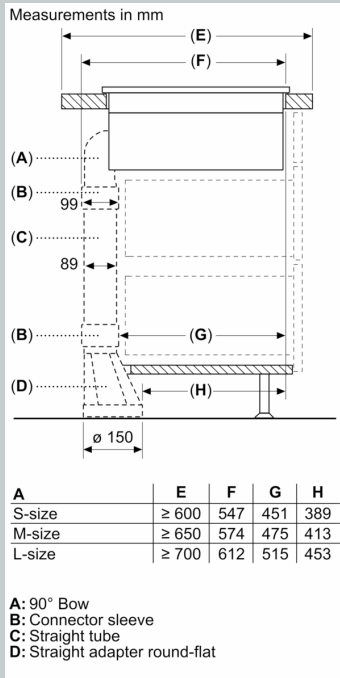
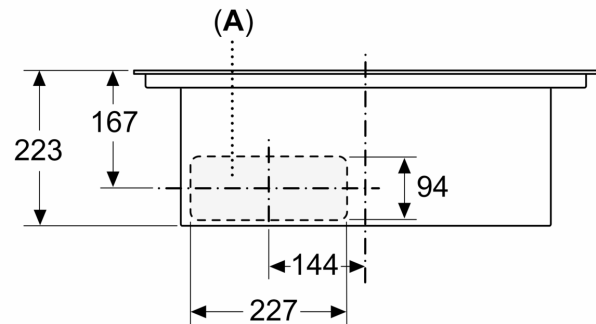
 measurements in mm
 Front view

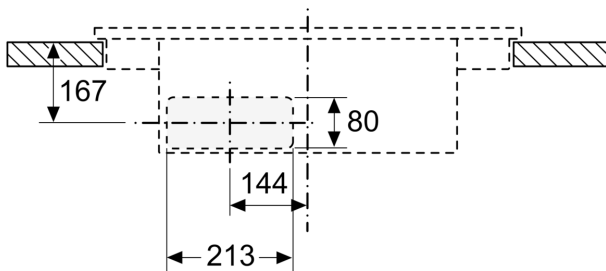
A: Connected directly at the rear

 measurements in mm
 Front view - unit cut-out
 for unducted recirculation

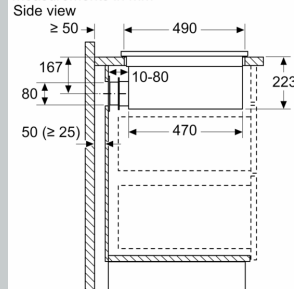
measurements in mm



When installing directly against outer walls that are not insulated ($\mu \geq 0.5 \text{ W/m}^2\text{°C}$), we recommend using partially or fully ducted recirculation configurations.

Dimensioned drawings

measurements in mm

Front view

