



Vela Island Hood
Instruction Manual

**VEL410BK,
VEL410CO
VEL410GD**



Contact Caple on 0117 938 7420 for spare parts or www.caple.co.uk

CONTENTS

Introduction	3
Safety Instructions	4
Environmental Protection	10
Installation	11
Replacing the Charcoal Filter	14
Operation - Touch Control	15
Remote Control	16
Care and Maintenance	17
Troubleshooting	20
Product Dimensions	21
Caple Contact Details	24

INTRODUCTION

Thank you for choosing this Caple extractor hood.

To ensure that you get the best results from your new extractor, we strongly suggest that you read this instruction manual thoroughly before use. If treated with care, your Caple extractor should give you years of trouble-free use.

To register ownership, please follow the instructions on the guarantee card supplied with the appliance or visit **www.caple.co.uk** and register here.

This instruction manual is designed to provide you with all the required information related to the installation, use and maintenance of the appliance.

This hood is designed to extract unpleasant odours from the kitchen; it is not intended to extract steam. In order to operate the unit correctly and safely, please read this instruction manual carefully before installation and use.

The cooker hood uses high quality materials and is made with a streamlined design. Equipped with an electric motor and centrifugal fan, it provides strong extraction with low noise. It also features non-stick grease filters and an easy installation.

IMPORTANT

This appliance must only be used for the purpose it is intended. Other types of use are not permitted and may prove dangerous. Caple will not be held liable for any damage caused by the incorrect use of the appliance.

Do not use any accessories or attachments not recommended by Caple as this may result in fire, electric shock or injury.

To protect against fire, electrical shock and injury to persons, do not immerse cords or plugs in water or any other liquid.

Never touch the appliance with wet or damp hands.

Never pull the power cable as you could damage it. If the appliance is faulty, do not attempt to repair it. Isolate it from the mains electric supply and contact Caple Service either by phone

0117 938 7420 or email service@caple.co.uk

Keep all packaging (including plastic bags, polystyrene foam etc) out of the reach and away from children.

Do not rest large or unstable objects on any part of the appliance.

IMPORTANT

Caple cannot be held responsible for injuries or losses caused by incorrect use or installation of this product. Please note that Caple reserve the right to invalidate the guarantee supplied with this product following incorrect installation or misuse of the appliance. Under no circumstances should any external covers be removed for servicing or maintenance except by suitably qualified personnel.

SAFETY INSTRUCTIONS

- Never let children operate the machine.
- The cooker hood is for home use only, not suitable for barbecuing, restaurants or other commercial purposes.
- The cooker hood and its filter should be cleaned regularly in order to keep in good working condition.
- Clean the cooker hood according to the instruction manual to reduce the risk of fire.
- When using a gas hob, do not leave naked flames under the extractor.
- Before connecting this appliance check that the power supply cord is not damaged.
- If the room where the hood is to be used contains a fuel burning appliance such as a central heating boiler then its flue must be of the sealed or balanced flue type. If other types of flue or appliances are fitted ensure that there is an adequate supply of air to the room.

- The air must not be discharged into a flue that is used for exhausting fumes from appliances burning gas or other fuels.
- Regulations concerning the discharge of air have to be conformed to.
- Do not flambé under the cooker hood.
- Never leave frying pans unattended during use as overheated fats and oils may catch fire.
- To ensure the best performance, we recommend switching on the extractor 15 minutes before cooking and leave it running 15 minutes after. This will ensure that the air in the kitchen is being circulated before cooking commences and the air is being cleaned after cooking has finished.
- The performance of your extractor will vary depending on a number of factors. These include type of extraction, room volume, length of ducting, ventilation available and the cleanliness of the filters.
- This appliance is not intended for use by persons (including children) with reduced physical, sensory or mental capabilities, or lack of experience and knowledge, unless they have been given supervision or instruction concerning use of the appliance by a person responsible for their safety.
- Children should be supervised to ensure that they do not play with the appliance.

- Cleaning and user maintenance must not be made by children without supervision.
- Never immerse the appliance in water.
- To avoid all risk, if the power cable is damaged, it must only be replaced by a Caple appointed engineer.
- Appliances can be used by persons with reduced physical, sensory or mental capabilities or lack of experience and knowledge if they have been given supervision or instruction concerning use of the appliance in a safe way and understand the hazards involved.
- Children must not play with this appliance.
- When not in use and before cleaning, always isolate the appliance from the electrical supply.

CAUTION:

- Accessible parts may become hot when used with cooking appliances.
- This appliance can be used by children aged from 8 years and above and persons with reduced physical, sensory or mental capabilities or lack of experience and knowledge if they have been given supervision or instruction concerning use of the appliance in a safe way and understand the hazards involved.

ELECTRICAL SHOCK HAZARD

- This unit must be correctly earthed. If in doubt seek advice from a suitably qualified engineer.
- Failure to follow these instructions can result in death, fire, or electrical shock.
- If the appliance is not provided with a non-separable flexible cable and plug, or with another device ensuring omni-polar disconnections from the grid, with an opening distance between contacts of at least 3mm, then such disconnecting devices must be supplied within the fixed installation.
- The electrical safety of this appliance can only be guaranteed when correctly earthed. It is essential that this standard safety requirement is met. If in any doubt please have the electrical installation tested by a qualified electrician.
- This appliance must be connected to the mains by a competent person. We recommend that the appliance is connected by a qualified electrician who is a member of the N.I.C.E.I.C who will comply with the I.E.E and local regulations. Electrical information can be found on the rating plate.

WARNING: KEEP BATTERIES AWAY FROM CHILDREN

- Always keep batteries away from children to prevent swallowing. If ingestion does occur, however, be aware that initial symptoms may be similar to other childhood illnesses such as coughing, drooling and discomfort.
- Store batteries out of reach of children in a cupboard, drawer or locker inaccessible to your children is the best place to store your batteries.
- Do not change batteries in the presence of children.
- Bring waste button batteries to a collection point so they can be recycled. Batteries at the end of life should be disposed of appropriately.

APPROPRIATE USE:

- This appliance is intended to be used in household and similar applications such as:
 - › Staff kitchen areas in shops, offices and other working environments.
 - › Farm Houses.
 - › By clients in hotels, motels and other residential type environments.
 - › Bed and breakfast type environments.



ENVIRONMENTAL PROTECTION

Waste electrical products should not be disposed of with household waste. Please recycle where facilities exist. Check with your Local Authority or retailer for recycling advice. This appliance is marked according to the European directive on Waste Electrical and Electronic Equipment (WEEE).

By ensuring this product is disposed of correctly, you will help prevent potential negative consequences for the environment and human health, which could otherwise be caused by inappropriate waste handling of this product. The symbol on the product indicates that this product may not be treated as household waste. Instead it shall be handed over to the applicable collection point for the recycling of electrical and electronic equipment. Disposal must be carried out in accordance with local environmental regulations for waste disposal.

For more detailed information about treatment, recovery and recycling of this product, please contact your local council, your household waste disposal service or the retailer where you purchased the product.

WARRANTY

Your new appliance is covered by warranty. The warranty card is enclosed - if it is missing, you must provide the following information to your retailer in order to receive a replacement: date of purchase, model and serial number. Registration can also be completed online by visiting www.caple.co.uk.

Ensure you keep your warranty card safe, you may need to show it to Caple Service together with proof of purchase. If you fail to show your warranty card you will incur all repair charges.

Spare parts are only available from Caple Service and spare parts authorised centres.

CE DECLARATIONS OF CONFORMITY



This appliance has been manufactured to the strictest standards and complies with all applicable legislation, Low Voltage Directive (LVD) and Electromagnetic Compatibility (EMC).

UKCA DECLARATIONS OF CONFORMITY



This appliance has been manufactured to the strictest standards and complies with all applicable legislation.

TECHNICAL FICHE

This appliance conforms to all current and applicable energy regulations. To view the Technical Fiche that supports the energy labelling data, please visit the product page on our website www.caple.co.uk

INSTALLATION

PREPARE FOR THE INSTALLATION:

Before beginning the installation, ensure the extractor is not connected to the mains supply.

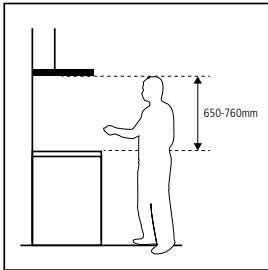

The cooker hood should be placed at a minimum distance of 650-760mm above the hob. It is the manufacturer of the hob who determines the clearance required and the clearance quoted by the hob manufacturer must be followed. In the absence of any instructions supplied with a gas hob, the minimum distance between the hob and the hood must be at least 760mm.

WARNING :

The electrical connection must correspond to the electrical requirement detailed on the rating plate. This is located inside the cooker hood.

After installing, check the appliance is operating correctly by selecting each speed and switching the light on and off.

The appliance is suitable for recirculation only, and cannot be vented externally. In recirculation mode the air and fumes conveyed by the appliance are cleaned both by a grease filter and by an active charcoal filter, and put again into circulation.

When installed above a gas hob or range cooker, do not use all the gas burners simultaneously for prolonged periods of time at the maximum setting (max. 15mins). There can be a risk of burns if the housing or extractor surfaces become hot, and there is also a risk that the extractor can become damaged due to excessive heat. If 3 or more burners are used simultaneously, operate the extractor at the maximum setting.

Never operate the gas hob without pans situated on the burners as the excess heat can damage the extractor.

INSTALLATION

Place the fixing bracket on the ceiling and mark the position of the holes. The fixing plate should be securely fixed to the ceiling.

1. 4 x ST6 (40mm) screws for wooden ceilings.
2. 4 x M6 (60mm) expansion bolts for cement ceilings.

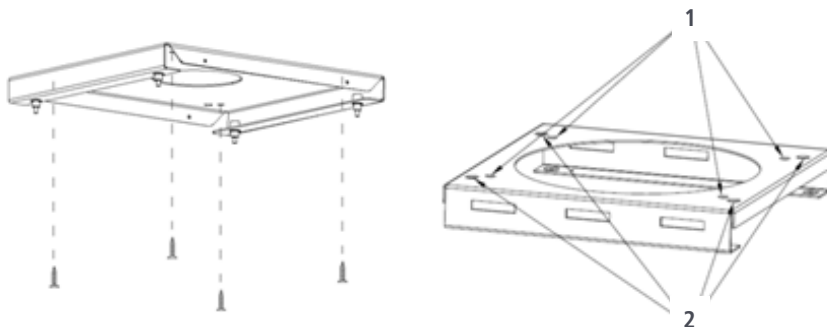

- › Pass the power cable through the carbon filter support. Gently lower the filter support until it rests on the hood.
- › Slide the charcoal filter onto the power cable and lower it down so that it rests on top of the support.
- › Pass the power cable through the metal top cover. Place it on top of the charcoal filter.

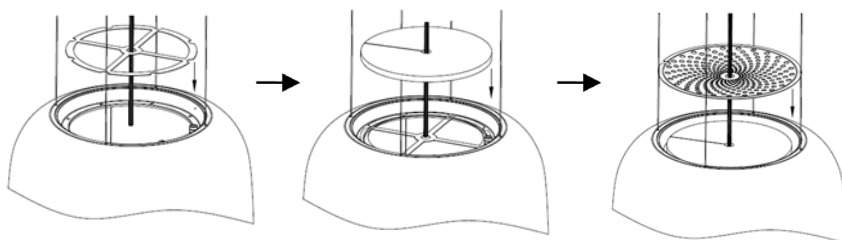

- › Pass the fixing wires and the power cable through the fixing bracket cover.

NOTE:

The next stage of the installation process **MUST** be completed by two people.

- › Fix the 4 steel wires to the fixing bracket using the wire lockers.
- › Connect the power cable.
- › Adjust the steel wires to a suitable length and check they are equal. This will ensure the hood is perfectly parallel to the ceiling and the correct position for use.

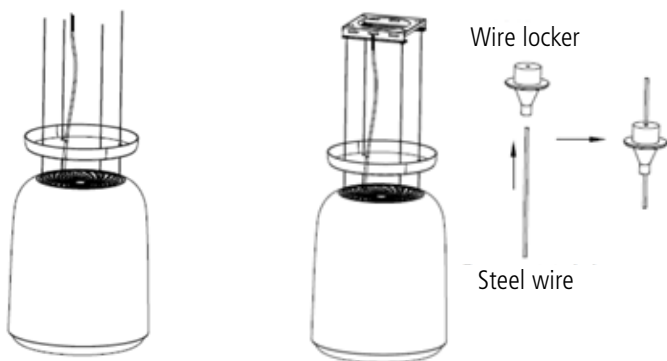

- › Push the fixing bracket cover up to the fixing bracket. Magnets will fix it in place.



WARNING:

Failure to install the screws or fixing device in accordance with these instructions may result in electrical hazards.

REPLACING THE CHARCOAL FILTER

An activated charcoal filter can be used to trap odours. In order to replace the charcoal filter, first remove the metal top cover. Remove the existing charcoal filter by gently lifting it upwards and sideways off of the power cable. It is suggested that a second person support the hood while this is being done to help prevent damage.

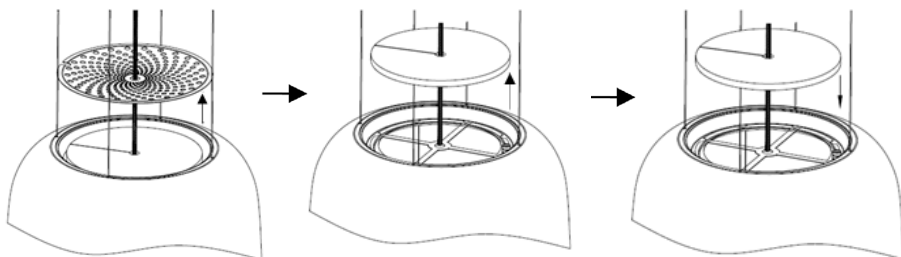

Fit the activated charcoal filter by reversing the removal steps. Slide the filter into the centre of the power cable and lower onto the filter support, then lower the metal top cover on top.

NOTE:

Make sure the filter is securely in position. Otherwise, it may loosen and be dangerous.

When using a charcoal filter, the extraction power may be slightly reduced.

We recommend replacing this filter every 6 months. Replacement filters (CAP82CF) can be purchased directly from www.caple.co.uk

OPERATION - TOUCH CONTROL

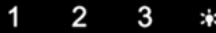

1 **LOW SPEED BUTTON**

Is suitable for simmering and cooking which does not produce much steam or odour.

2 **MEDIUM SPEED BUTTON**

Airflow speed is ideal for extracting with standard cooking.

3 **HIGH SPEED BUTTON**

When a high amount of steam or odours are produced, use the high speed setting for the most effective extraction.

TURN ON THE HOOD:

Press and hold either 1/2/3 to turn the hood On.

TURN OFF THE HOOD:

Press the currently selected speed. For example, if speed 2 was selected, press 2 again to turn the hood Off.

LIGHT BUTTON:

Turns the light ON/OFF.

CONTROL THE BRIGHTNESS:

When the light button is first pressed, the brightness will be 50%.
Press and hold the light button for 100% brightness.

REMOTE CONTROL

NOTE:

Battery is NOT supplied with the remote control. 1 x CR2025 battery is required.



ON/OFF BUTTON:

Turns the extractor ON/OFF.



FAN SPEED BUTTON

Each press changes the speed of extraction in the following order '1-2-3-1'.



LIGHT BUTTON

Turns the light ON/OFF.

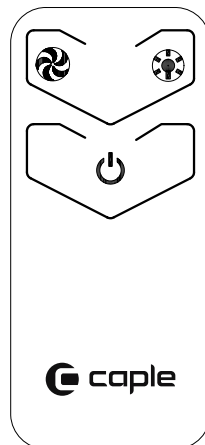

CONTROL THE BRIGHTNESS

When the light button is first pressed, the brightness will be 50%.
Press and hold the light button for 100% brightness.

The remote control supplied with this extractor requires a battery. Batteries are not supplied with this product and need to be purchased separately.

WARNING:

Keep batteries away from children.

- › Always keep batteries away from children to prevent swallowing. If ingestion does occur, however, be aware that initial symptoms may be similar to other childhood illnesses such as coughing, drooling and discomfort.
- › Store batteries out of reach of children in a cupboard, drawer or locker inaccessible to your children is the best place to store your batteries.
- › Do not change batteries in the presence of children.
- › Bring waste button batteries to point so they can be recycled. Batteries at the end of life should be disposed of appropriately.

CARE AND MAINTENANCE

IMPORTANT:

Before cleaning or maintenance please switch off the electricity supply and remove the plug from the wall.

REGULAR CLEANING

Use a soft damp cloth with lukewarm mildly soapy water or household cleaning detergent. Never use metal pads, chemicals, abrasive material, abrasive cleaning creams or stiff brushes to clean the appliance.

CLEANING THE GREASE FILTER

Clean the filter every month to help minimise the risk of fire. The filter collects grease, smoke and dust, therefore the filter is directly affecting the efficiency of the cooker hood. If not cleaned, the grease residue (which is potentially flammable) will saturate the filter. It can be easily cleaned with warm water and washing up liquid, alternatively the filters can be cleaned in your dishwasher. Please ensure no other items are washed with the filters, they must be washed separately to prevent food becoming trapped in the gauze. Cleaning the grease filters in the dishwasher may lead to discolouration, this is normal and is not a fault with the product.

The grease filter is located underneath the hood and surrounds the control panel. It is fixed by magnets, therefore to remove, hold both sides of the grease filter and carefully pull downwards (Fig.1). To re-install, simply push it back into place (Fig.2).

FIG 1

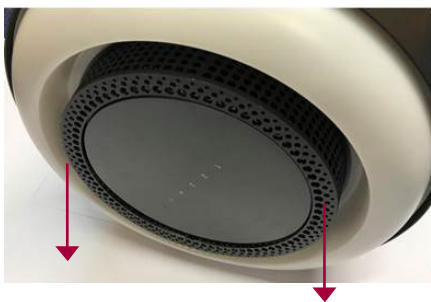
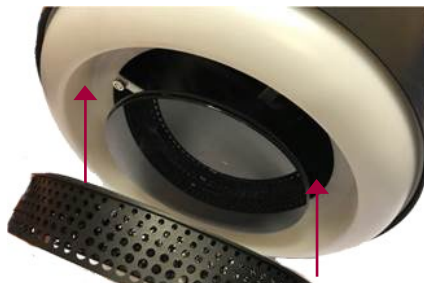

FIG 2



REPLACING YOUR CHARCOAL FILTER

The charcoal filter traps your cooking odours and needs to be replaced, this can vary depending on how frequently the cooker hood is used. We recommend replacing the filter at least every 6 months.

This extractor uses a CAP82CF charcoal filter. Filters can be purchased directly from www.caple.co.uk.

REPLACING THE LED LIGHT

NOTE:

The LED light replacement must only be performed by qualified personnel.

1. The extractor must firstly be uninstalled and taken down from the ceiling bracket.
2. Remove the coloured outer casing by removing the 4 fixing screws (Fig.1).
3. Remove the grease filter (Fig.2).
4. Remove the Light panel/casing by removing the 4 fixing screws (Fig.3)
5. The LED light can now be removed by loosening the 4 fixing screws, and replacing with a new LED light (Fig.4)
6. Reverse these steps to reassemble.

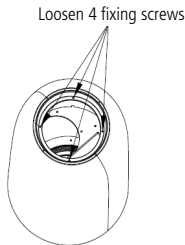

Fig.1

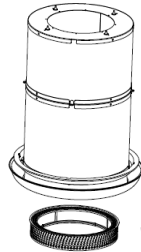

Fig.2

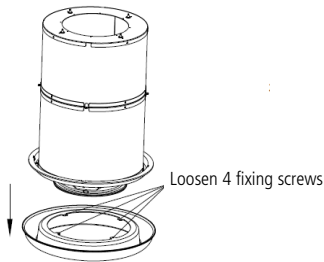

Fig.3

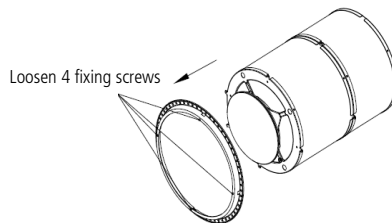

Fig.4

For spare parts, including replacement LED lights, please contact Caple service:

T – 0117 938 7429

E – service@caple.co.uk

TROUBLESHOOTING

FAULT	CAUSE	SOLUTION
The lights on, but the fan does not work	The fan blade is jammed.	Switch off the unit and contact Caple Service. To be repaired by qualified service personnel only.
	The motor is damaged.	
The lights and fan do not work	A blown fuse.	Replace the fuse.
	The power cord is loose.	Ensure the extractor is correctly connected to the mains power supply.
Serious vibration of the unit	The fan blade is damaged.	Switch off the unit and contact Caple Service. To be repaired by qualified service personnel only.
	The fan motor is not fixed tightly.	Switch off the unit and contact Caple Service. To be repaired by qualified service personnel only.
	The unit is not hung correctly on the bracket.	Take down the unit and check whether the bracket is in the correct location.
The extraction performance is not good	The filter requires cleaning or there is too greater distance between the hood and the hob	Clean the grease filter as directed in the 'Care and maintenance' section. Replace the charcoal filter. Readjust the distance of the hood so that it is 65-75cm from the hob below.

If the above table has not solved the problem please contact Caple Service by phone on **0117 938 7420** or by email **service@caple.co.uk**

PRODUCT DIMENSIONS

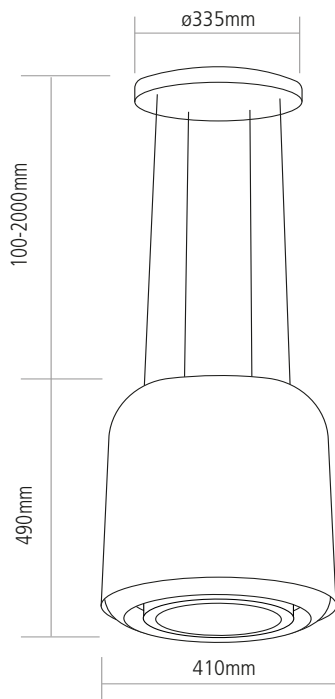

NOTES:

NOTES:



Caple Service
Fourth Way
Avonmouth
Bristol
BS11 8DW

T: 0117 938 1900
E: service@caple.co.uk
www.caple.co.uk